

Round balers
IMPRESS

 **PÖTTINGER**

The perfect flow.



The new dimension.



Agriculture needs reliability. Regardless of whether the sun is shining or it is raining, regardless of whether baling straw, hay or silage – the reliability of our round balers in all operating conditions is a key feature of the PÖTTINGER IMPRESS.

Contents

IMPRESS round balers

Maximum versatility	4
The highest forage quality	6
Reliability & convenience	10
Durability & service life	12

IMPRESS technology

Pick-up	18
Rotor	20
Knife bank	22
Net binding / Greasing	26

IMPRESS models

Fixed chamber balers	28
Variable chamber balers	32
Baler & wrapper combinations	36

Digital agricultural technology

Intelligent operation	40
-----------------------	----

Accessories / Technical data

Accessories	42
Technical data	44
Original parts	46

All information on technical data, dimensions, weights, output, etc. is approximate and is not binding.

Maximum versatility



Versatility for all crop types

Regardless of whether in wet or dry conditions, straw, hay or silage, here is one machine for all operating conditions.

- Controlled pick-up for perfect ground tracking and cleanly collected crop.
- LIFTUP rotor technology for a natural flow of crop. Guaranteed to get the bale started with four starter rollers.

Reliable bale start in all operating situations, even with all 32 knives engaged:

- Wet or dry conditions.
- Straw, hay or silage.
- One machine for all conditions, even as a variable baler – unique on the market.

High capacity performance

The best possible performance, everywhere and any time:

- Controlled floating pick-up for maximum intake.
- Innovative LIFTUP overhead rotor makes the highest performance possible.
- Two active augers on each side for high capacity feed to the rotor.

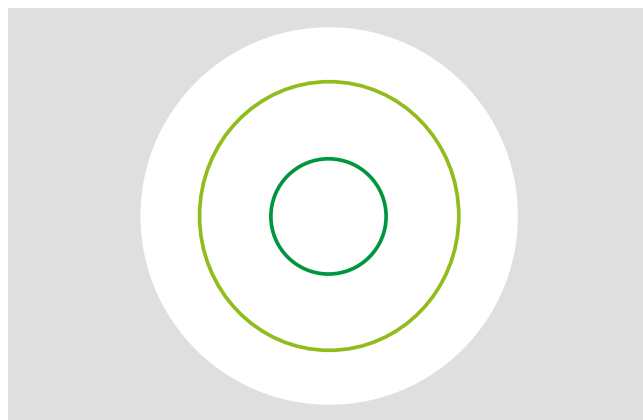
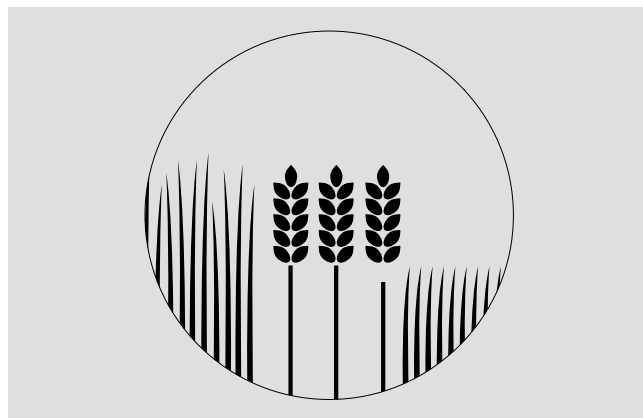
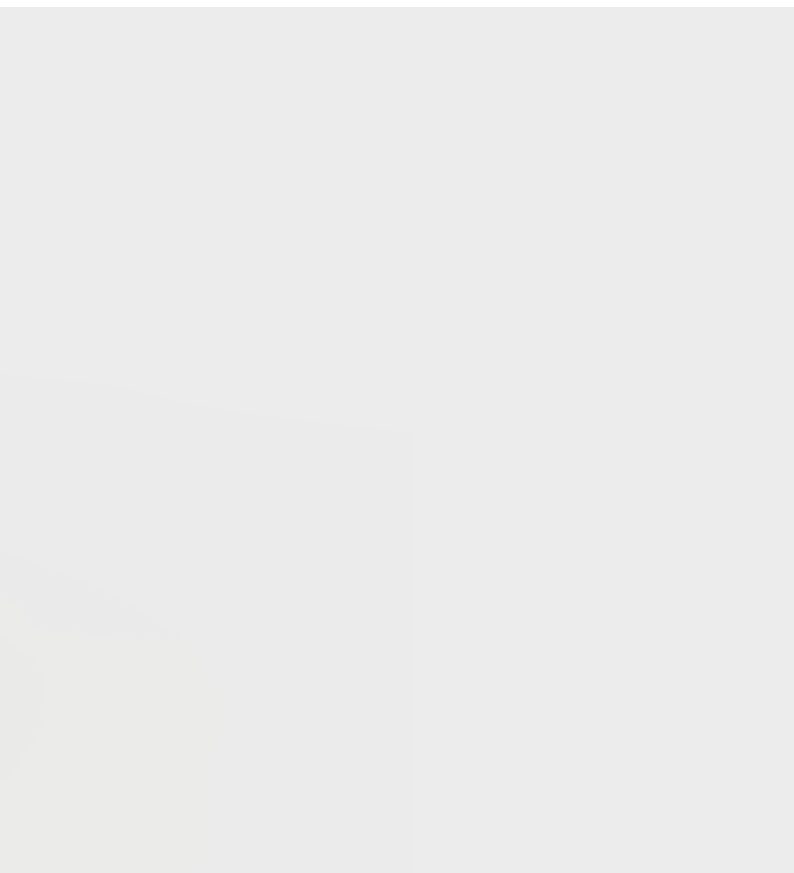

Baling pressure can be set flexibly across three zones

- 3-zone soft core setting on variable balers.
- Up to 6 preselects for crop-specific parameters in hay, straw and silage.

Italian farm appreciates flexibility

Farming business Boldini F.lli s.s. has a wide spectrum of crops, all of which can be baled using the IMPRESS. "We are amazed at the quality and performance of the IMPRESS. Harvesting silage, hay or straw – the IMPRESS always delivers a very good result."

The highest forage quality



The best forage in every situation

The PÖTTINGER IMPRESS guarantees the best possible handling of every crop, in silage, hay or straw. We redefine established systems and provide loader wagon chopping quality in round balers for the first time, offering the highest possible forage quality.

Unique 1.42 in / 36 mm chopped length

A short chop length of 1.42 in / 36 mm is a world first for round balers and leads to high compression of the crop.

- An increased bale weight with all harvest materials (silage, hay, straw) of around +15% when moving from 16 to 32 knives.
- Reduces storage area required.
- Less handling time.
- Lower transport and storage costs.
- Lower overall costs thanks to lower netting and film usage.
- The best possible forage quality for a lower cost.

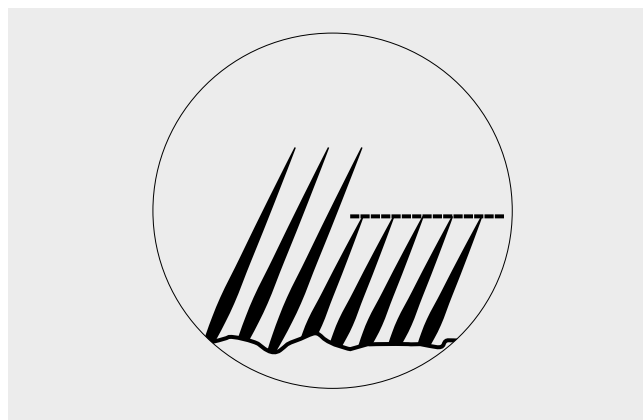
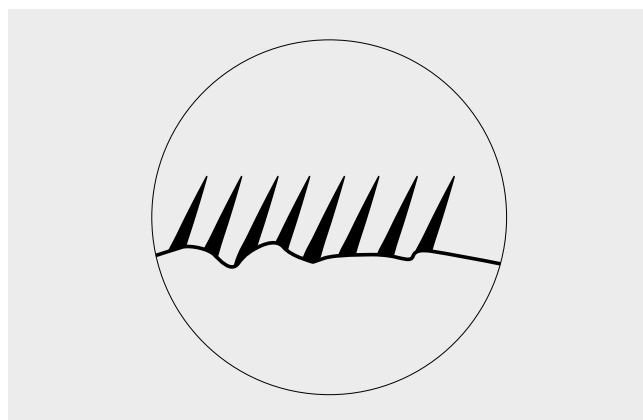

Silage – additional advantages of shorter chop length

- Higher compression, heavier bales – improved fermentation.
- Homogeneous mixing – improved fermentation stability
- Easier bale cutting when feeding.
- Less mixing needed by feed mixer wagon.
- Less power required.

Straw – additional advantages with short chop material

- No additional chopping needed – lower costs.
- Optimum stalk breakage – higher porosity.
- No dust generated during handling and distributing.
- Power saving of up to 20% compared to baler-mounted straw chopper.
- Ideally chopped structure for TMR feeding.

The highest forage quality



Bale quality

The innovative LIFTUP rotor on the PÖTTINGER IMPRESS enables high baling output, while the bale chamber is fed with a uniformly wide blanket of crop. The farmer benefits in every way and this greatly reduces the amount of weaving needed to produce perfectly shaped bales. The result is greater convenience for the driver and bales that keep their shape.

Bales should be wrapped within two hours of baling for the best fermentation.

Better still: use a baler & wrapper combination.

IMPRESS baler & wrapper combinations

Direct wrapping, continuous loading and double bale placing. An innovative, fast, high throughput wrapper to match the high output baler. Adjustable film dispenser for bales between 3.61 – 4.92 ft / 1.10 and 1.50 m diameter.

Unique 1.42 in / 36 mm chopped length to the edge of the bale

- Individual knife protection system for consistent chopping quality.
- TWIN BLADE reversible knives.
- Replacement knives are always on board.
- Double the service life – long term uniform chop consistency
- Sharp knives reduce the power required to drive the knife bank by around 20%.

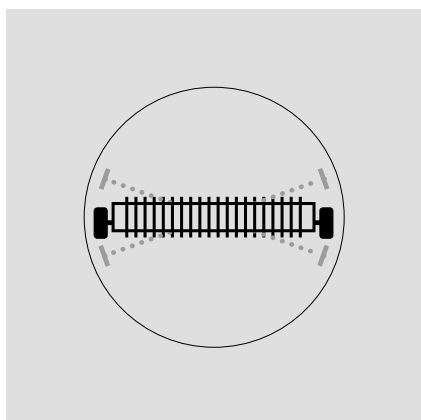

Ground tracking & crop take-up

Unique floating pick-up system with 4.72 in / 120 mm of vertical travel at the tines.

- Weight alleviation on pick-up for perfect ground tracking and exact contouring.
- Clean forage and best silage quality.

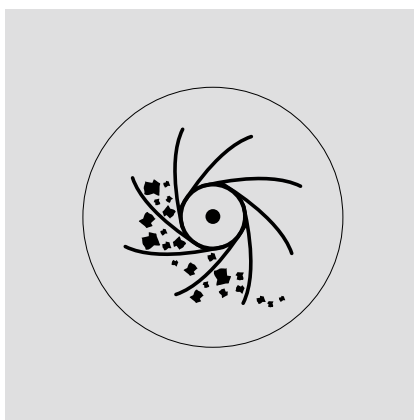

Smooth crop flow

Reduced potential for contamination

- Lower crop losses due to disintegration with an optimised crop flow.
- Reduced disintegration losses thanks to controlled pick-up.
- Disintegrated material is fed back into the crop flow.
- Because the chopping system is positioned above the crop flow, it is less prone to contamination.
- Nonstop individual knife protection system.
- Short material falls away from knife springs avoiding blockages unlike conventional systems.



Austrian farmer Berer relies on chopping quality

“The chop quality is really the best. Our automatic feeding system mixes eight times a day for four minutes. With our previous quality bales chopped with 16 knives the mixing procedure took two minutes longer – i.e. in total 16 minutes longer every day. The chop quality of the IMPRESS saves us both time and electricity.”

Reliability & convenience



Our customers put their trust in our reliability and with the PÖTTINGER IMPRESS, you get that in double helpings. Firstly because our innovative technology makes each working step easier by making operation a lot more convenient. Secondly because we offer the unique advantage of reliability in all situations, ensuring that you make the most of the IMPRESS's unbeatable technical features regardless of which material you are baling and in which conditions you are working.

Reliable operation

Regardless of whether the sun is shining or it is raining, regardless of whether baling straw, hay or silage – the reliability of our round balers in all operating conditions is a key feature of the PÖTTINGER IMPRESS.

- Best possible processing of every type of material (silage, hay, straw) in every situation.
- Reliable bale start thanks to tangential crop flow in all operating conditions, even with all 32 knives engaged.

Working convenience

Agriculture needs straightforward operations. While we cannot relieve our farmers and contractors of their work, we can make it easier. We do that by redefining the quality of life with our innovative standards. The IMPRESS round baler demonstrates how performance and convenience can work together perfectly.

Reduced weaving

- Patented auger configuration.
- The bale chamber is fed uniformly across its whole width.
- This greatly reduces the amount of weaving needed to produce perfectly shaped bales.
- Alleviates driver fatigue.
- Nicely shaped bales with strong edges.

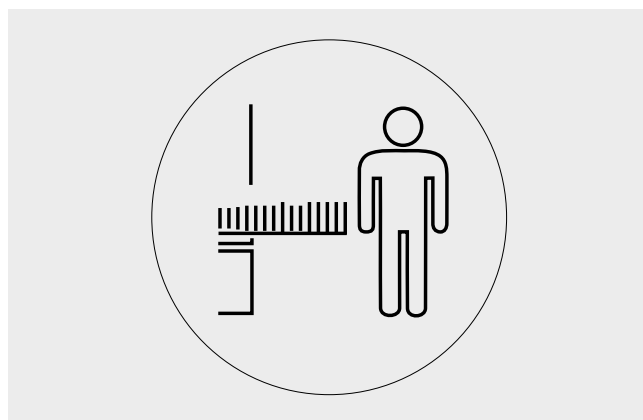

Convenient and safe

Unique ease of maintenance

- The highest possible level of safety and convenience with maintenance taking place at an ergonomic workbench height outside the bale chamber.
- Service the knife bank ergonomically while standing upright and outside the danger area of the baler..
- The highest level of safety.

Pre-Selection of knives

- Patented knife group switching.
- Flexible selection of the number of knives that are in operation (0 – 16 / 16 / 32 knives).

IMPRESS impresses a Polish farming professional

In addition to high performance, Janusz Jelenkowski also appreciates the convenience of being able to access the knife bank easily: “With the number of hectares I have to cover a year, convenient and safe maintenance is a key issue. These facts in combination with the good service offered by Pöttinger make the IMPRESS unbeatable.”

Durability & service life



Variable chamber model for all operating conditions

The variable chamber models have three endless belts with a hydraulically-adjustable pressure-controlled belt tensioner. The three endless belts make sure the bale rotates in every situation, even with hot, dry straw.

- Wet or dry conditions.
- Straw, hay or silage.
- One machine for all conditions, even as a variable baler – unique on the market.

That's what contractors want

Four starter rollers on fixed chamber and variable balers

The bale chamber has two starter rollers above and also below the throat. As a result a reliable bale start in all operating situations is guaranteed, even with all knives engaged. All the rollers in the bale chamber are designed for the highest pressures to ensure the greatest reliability.

- The baler rollers are driven by 1 1/4 inch high performance roller chains.
- Heavy duty self-aligning bearings with a diameter of 1.97 in / 50 mm.
- Multi spline profile reliably transmits power to the starter and compression rollers.



Automatic pick-up and tailgate (PRO models)

- The pick-up is raised automatically when binding starts.
- Tailgate opens automatically after bale has been netted.
- Tailgate closes automatically (only if bale kicker is in use).
- Tailgate is fitted with shock absorber (PRO and MASTER).

Net wrapping

The bales are wrapped tightly in the set number of layers of net. The net wrapping system also boasts several special features: Using a feeder plate, the net wrap is fed reliably into the bale chamber.

Output and chopped length are what count in France

Stéphane Simon of GAEC Simon France is enthusiastic: "The IMPRESS gives me maximum versatility in operation, regardless of whether it is with grass or straw. In the field I have witnessed the performance of the floating pick-up, the high chopping quality with the 32 reversible knives as well as perfect bale formation with a very high density. I am also really pleased with the automatic tailgate function, which has saved me a lot of time."

Durability & service life



Easy to attach

Universal drawbar

The height of the universal drawbar can be infinitely variable adjusted using two turnbuckles. Rapid and precise adaptation to every tractor.

- All hoses and cables are routed tidily through the hose holder.
- A parking stand makes it easy to attach and detach, fitted to the left-hand side in the direction of travel.

Hydraulic adjustable drawbar

- Optional on PRO models.
- High ground clearance under the pick-up and even higher capacity baling hay and straw.
- Drawbar shock absorbers for even smoother bale transfer and road transport.

For a safe journey

Air brakes or hydraulic brakes

Axles equipped with large diameter brakes enhance safety while driving on the road and in steep terrain. Solo machines are available without brakes as an option.



Smoothest ride

Tandem axles

Optional on solo machines for the smoothest ride in the field and on the road.

Tyres:

380/55-17, 500/50-17, 520/50 R 17, 520/55 R 22.5, 500/60 R 22.5.



Tyres on demand

IMPRESS MASTER standard tyres
380/55-17,
optional 500/50-17, 520/50 R 17,
500/60 R 22.5, 620/40 R 22.5,
520/55 R 22.5.

IMPRESS PRO standard tyres
500/50-17
optional 520/50 R 17, 500/60 R 22.5,
620/40 R 22.5, 520/55 R 22.5.

Standard tyres on baler & wrapper
combinations with tandem axles
520/55 R 22.5,
optional 500/60 R 22.5.



Automotive-quality paint

PÖTTINGER painting line technology incorporates cathoretic dip priming and powder coating.

- The most environmentally friendly painting methods.
- Production and processing without solvents.
- High elasticity and long service life.
- No cracks form in the paint as a result of stress or deformation.
- Good corrosion protection.
- All cavities are coated without exception.
- Excellent UV resistance.

Round balers





The PÖTTINGER product range

**IMPRESS F fixed chamber balers,
IMPRESS V variable balers**

IMPRESS MASTER

IMPRESS 125 F MASTER,
IMPRESS 155 V / 185 V MASTER,
Chopping system with 16 knives,
PTO speed 540 rpm,
Pick-up width 6.73 ft / 2.05 m, optional 7.55 ft / 2.30 m,
SELECT CONTROL operator terminal.

IMPRESS PRO

IMPRESS 125 F PRO,
IMPRESS 155 V / 185 V PRO,
Chopping system with 32 knives,
PTO speed 1000 rpm,
Pick-up width 7.55 ft / 2.30 m,
POWER CONTROL operator terminal,
optional EXPERT 75 / EXPERT 100.

IMPRESS FC PRO / VC PRO baler & wrapper combinations

IMPRESS 125 FC PRO
IMPRESS 155 VC PRO
Direct wrapping, continuous loading and double bale placement. New, high performance, matched to the output of the baler.
The best forage quality thanks to the finished bale being wrapped immediately.

Pick-up



Pick-up with maximum capacity

Two pick-up widths

IMPRESS MASTER

Standard 6.73 ft / 2.05 m, with rigid jockey wheels,
optional 7.55 ft / 2.30 m with trailing jockey wheels.

IMPRESS PRO

Standard 7.55 ft / 2.30 m with trailing jockey wheels.

A controlled floating pick-up

The PÖTTINGER pick-up is controlled from both ends by a steel cam track.

- The tines are slightly trailing to sweep in a controlled arc and adapt ideally to contours. As a result clean forage is guaranteed.
- The active use of the full length of the tine up to the withdrawal point ensuring the forage is transferred to the rotor perfectly.
- Combined with the reduced speed of the rotor, the forage is not dragged, but fed actively into the rotor.
- Maximum conveying performance at high driving speeds.
- Reliable high intake performance, even in difficult harvesting conditions.

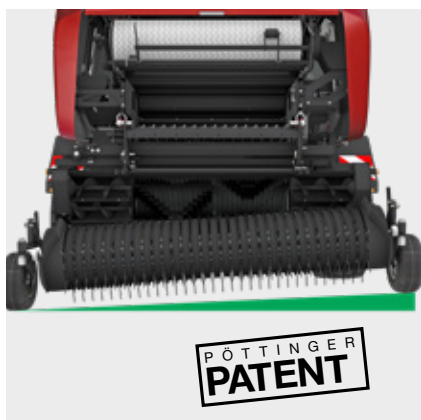

Best ground tracking Clean forage

Freedom of movement 120 mm

The pivoting point in the middle of the pick-up and two jointed support arms ensure the pick-up has complete freedom of movement with a unique vertical travel of 4.72 in / 120 mm at the tines.

Adjustable weight alleviation spring for perfect ground tracking and exact contouring.

To ensure perfect ground tracking when cornering, the 16 x 6.5-8 jockey wheels can be adjusted to ensure they make contact with the ground on precisely the same line as the tines.

Perfect forage flow

A swath roller with crop windguard and transfer rods guarantees perfect forage flow in every type of crop, even at high speed.

Two feed augers

Two augers on each side ensure optimum feeding. Particularly with dry material, these actively convey large volumes for enormous intake capacity.

- Jockey wheels can easily be height-adjusted.
- Pick-up float function with 8 settings for great flexibility in straw.
- A crop swath roller with a diameter of 7.87 in / 200 mm and optimised crop windguard transfer rods for highest rate of intake.

Overhead rotor



The perfect flow – unique crop flow path

Literally redefining the crop flow into the baler has brought about many positive advantages: Firstly, the new LIFTUP technology enables a natural flow of crop, so that the forage enters the bale chamber tangentially at an ideal angle. The long transfer throat ensures the crop is in even layers and tidily net wrapped. This helps the bale retain its shape even when handled multiple time.

- Tangential crop flow into bale chamber for a perfect start to the bale.
- Two starter rollers above and below the throat.
- The rotor has rows of tines arranged in a V with a diameter of 25.59 in / 650 mm.
- The loading rotor is mounted on self-aligning ball bearings at both ends.



Cleaning rotor



Any material that does fall through is fed back into the flow by the cleaning rotor. This is a unique design that solves the problem of disintegration of crop material with a higher number of knives. The result is a high baling performance with very low disintegration losses.

- Any disintegrated material is fed back via the cleaning rotor into the flow of crop. **1**
- Cleaning rotor. **2**

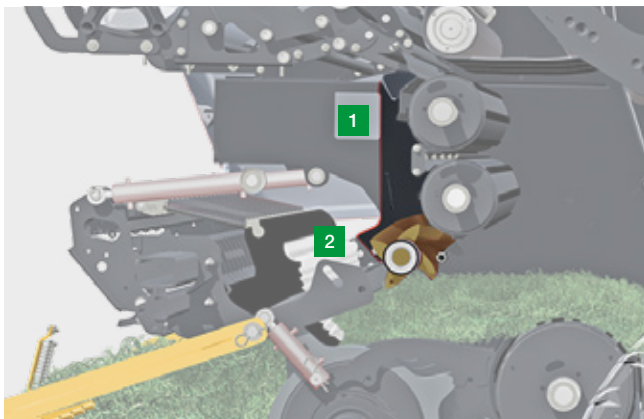

This is a key advantage especially when baling leafy forage such as lucerne because none of the nutritious leaves are lost.



Living agricultural technology

As experts, we at PÖTTINGER tackle the challenges you find in the field every day.

Tangential crop flow

The bale starts turning reliably in all operating conditions. Regardless of whether in wet or dry conditions, straw, hay or silage, here is one machine for all operating conditions.

Patented spiral configuration



- 0.39 in / 10 mm thick tine rings.
- High strength for reliable operation in stony areas.
- V-shaped for optimum flow into the chamber.

The bale chamber is fed uniformly across the whole width. This greatly reduces the amount of weaving needed to produce perfectly shaped bales.

IMPRESS PRO

Rotor for 32 knives **1**

IMPRESS MASTER

Rotor for 16 knives **2**

Agriculture needs straightforward operations. LIFTUP technology places the chopping system above the rotor. The higher the number of knives, the greater the importance the ease of maintenance becomes.

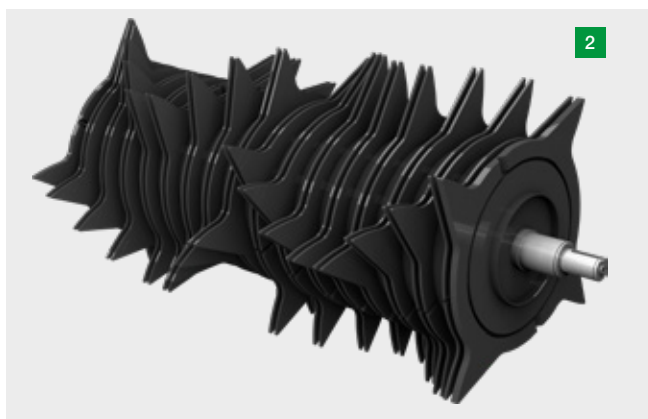
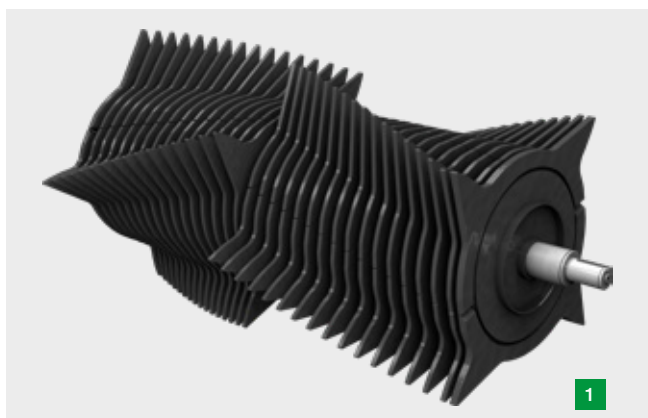

Chopping unit





Chopping quality

IMPRESS PRO model offers 1.42 in / 36 mm chopped length with 32 knives.

The new, pull-out FLEXCUT 32 short chop system features 32 TWIN BLADE reversible knives providing a theoretical chopped length of 1.42 in / 36 mm spread evenly across the entire rotor width.

PÖTTINGER, the world leader in loader wagons, has thus managed to integrate loader wagon chop quality into a round baler for the first time. Short chop not just for silage, but also for hay and straw, that is unique.

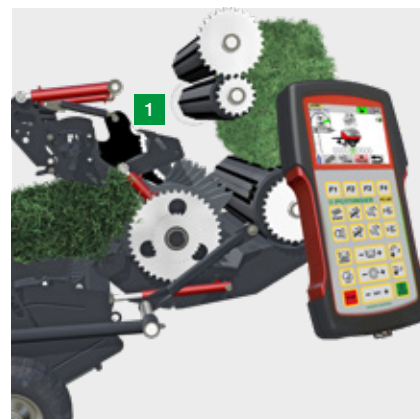

Top-mounted short chop system

- Advantages of the IMPRESS chopping system.
- NONSTOP individual knife protection system.
- Variable knife group switching offers more flexibility.
- TWIN BLADE knives – double the service life and replacements are always on-board. Unique amongst balers.

Knife quality

- The knives are produced from hardened tool steel and their pressed serrated edge ensures a precise chop.

Flexible chopping system floor

- If a blockage occurs, the cross section of the throat can be increased temporarily by lifting the chopping system roof. **1**
- This allows the blockage to be cleared easily and effortlessly.

Pull-out knife bank

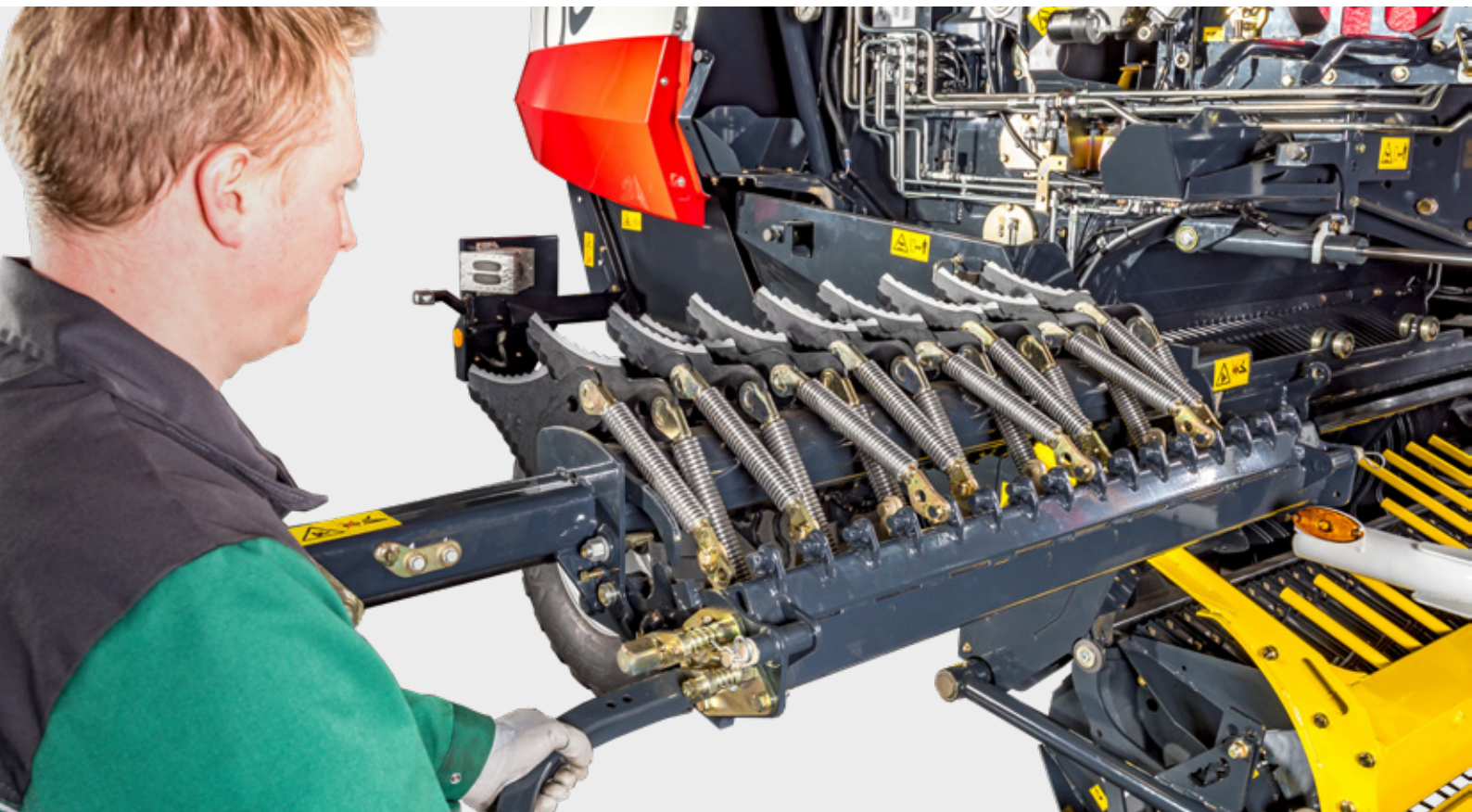

EASY MOVE now available on round balers A unique system

The IMPRESS models feature an EASY MOVE knife bank that pulls out to the side. This offers the highest level of safety and convenience. Maintenance takes place at workbench height outside the bale chamber, away from the hazardous area of the round baler. The higher the number of knives, the greater the importance the ease of maintenance becomes. The PÖTTINGER IMPRESS provides an ingenious and convenient solution.

Different chopping configurations

PRO 0 – 16 / 16 / 16 / 32 knives
MASTER 0 – 16 / 8 / 8 / 16 knives

Up to 16 knives can be disengaged on the knife bank (MASTER and PRO) to create different chopping configurations. These are always active when the knife bank is swung back in.

The knives on the shafts A and B can be pivoted either in or out.

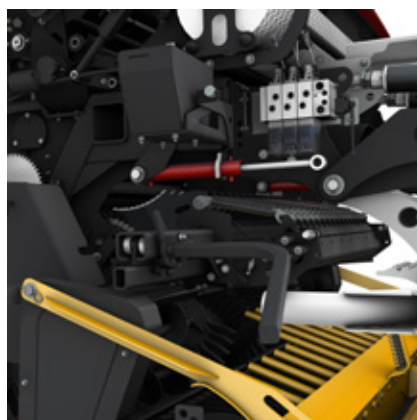
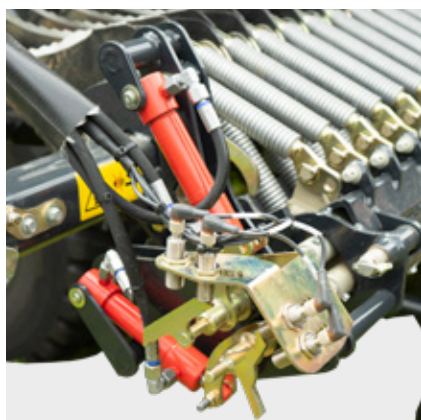

Variable knife group switching

16 knives on the knife bank
PRO 0 – 16 knives
MASTER 0 – 16 knives

On the square cross-section of the interlock shaft, the knife groups A and B are engaged and disengaged using a lever.

Shaft A
PRO 0 – 16 knives
MASTER 0 – 8 knives

Shaft B
PRO 16 knives
MASTER 0 – 8 knives

Hydraulic knife group selection

- Optional hydraulic knife group selection from the tractor cab on PRO models.

It's so easy with an IMPRESS

- Lower the pick-up and swing out the chopping system hydraulically.
- Remove the hydraulic cylinder, release the knife bank and pull out.
- Rotate the knife shaft. The knife bank is secured in its outer position and at the same time the knives are released centrally.

Maintenance-friendly

With the IMPRESS, maintenance is straightforward and simple. Another innovation is the use of TWIN BLADE reversible knives, which provide double the service life. Now it is no longer necessary to sharpen knives during a days work.

- Reserve knives are mounted on the right-hand side of the machine. Up to three spare knives can be carried.

Safe, convenient and time saving

- The knives can be reversed or replaced quickly and easily.
- Rotate the knife shaft back again to lock them in place. The knife bank is now ready to be pushed back in.
- Push in the knife bank, secure, attach the hydraulic cylinder, swing chopping system back in – job done!

Reliable / maintenance-friendly



Wrapped tight

Net wrapping

The bales are wrapped tightly with a predetermined number of layers of net wrap. The net wrap system boasts several special features: Using a feeder plate, the net wrap is fed reliably into the bale chamber. The net wrap is propelled into the bale chamber quickly.

IMPRESS MASTER

Start wrapping manually or in automatic mode once the bale has reached its set diameter.

IMPRESS PRO

Start net wrapping manually or in automatic mode, adapting to bale diameter.

Automatic system with ISO: Start wrapping while the machine is stopped.

Automatic time setting: Wrapping starts automatically after the bale has reached its set diameter. This is an advantage with POWER CONTROL terminals (without a speed signal).

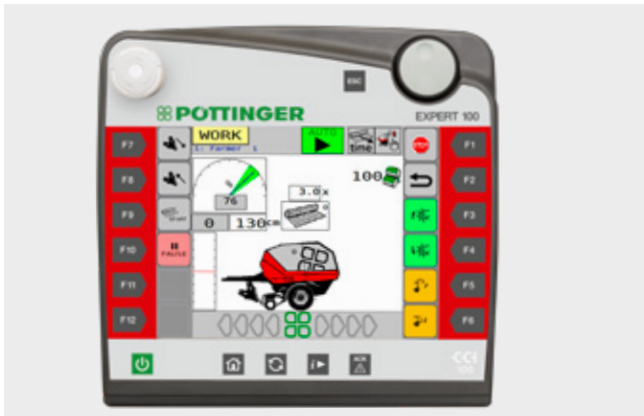

Movable net wrap feeder unit



When the movable net wrap feeder unit moves into the chamber, the net wrap brake is deactivated. As soon as the net wrap enters the bale chamber, the net wrap brake is applied so that the net wrap is tensioned and wraps tightly right from the beginning.

Maximum net wrap width 4.27 ft / 1.30 m, diameter up to 12.20 in / 310 mm. Infinitely-variable nett tension.



Changing the roll of net wrap

Pull back the tracking roller to activate the brake so that the tensioning block can be removed using a quick-release catch. Spare net wrap roll holders are located behind the covers on each side.

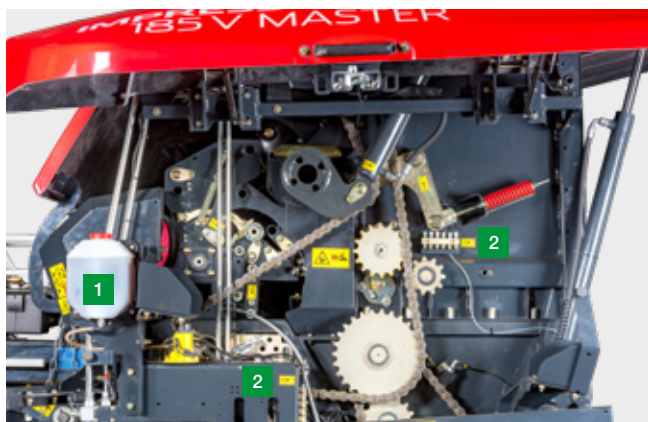

Maintenance-friendly

The automatic chain lubrication system optimises ease of maintenance and guarantees a long service life of the baler.

MASTER models

- Automatic chain lubrication. **1**
- Greasing of the bearings on the rollers and bale belt bearings via a central greasing point. **2**

PRO models

- Automatic chain lubrication. **1**
- Progressive greasing of the bearings on the rollers using a progressive distributor. One grease nipple.
- Automatic greasing system is optional. **2**



Large farm in the Czech Republic ZD Opařany

The flexibility of working with all crops and the 1.42 in / 36 mm chopped length were decisive for ZD Opařany, a large farm in the Czech Republic: "The chop consistency and the forage quality are absolutely great. The high bale density combined with the high baling pressure produces very compact, well formed and hard bales. They actually look like they have been machined on a lathe, simply perfect. The slide-out knife bank is a brilliant innovation. Now drivers can replace knives conveniently while standing next to the baler and do not need to climb into the baling chamber. It is not just safer, it also saves time."



Fixed chamber round balers



IMPRESS 125 F



IMPRESS 125 F MASTER

Chopping system with 16 knives,
PTO speed 540 rpm,
Pick-up width 6.73 ft / 2.05 m, optional 7.55 ft / 2.30 m,
SELECT CONTROL operator terminal.

IMPRESS 125 F PRO

Chopping system with 32 knives,
PTO speed 1000 rpm,
Pick-up width 7.55 ft / 2.30 m,
POWER CONTROL operator terminal,
optional EXPERT 75 / EXPERT 100.

Fixed chamber round balers



IMPRESS 125 F



IMPRESS 125 F MASTER / 125 F PRO

Fixed bale chamber 3.94 x 4.10 ft / 1.20 x 1.25 m

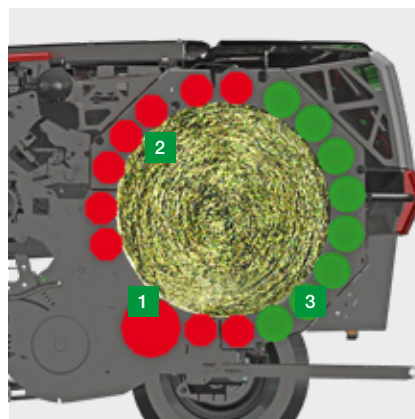

Reliable technology

Fixed bale chamber 3.94 x 4.10 ft / 1.20 x 1.25 m. The fixed chamber has 18 chain-driven rollers to shape uniform, highly stable bales. The material to be baled is compressed until the pressure on the tailgate sensor reaches the pressure set on the terminal. Nett binding takes place automatically or at the touch of a button, depending on the setting.

The front seven rollers make sure the bale rotates in every situation, even with straw.

- Two starter rollers above and below the throat. **1**
- Five drive rollers with a wall thickness of 0.18 in / 4.5 mm at the front, ensure the highest drive power for really compact bales. **2**
- Eight rollers with a wall thickness of 0.14 in / 3.5 mm in the tailgate to control bale shape. A hydraulic tailgate designed for the highest baling pressures. **3**

All rollers have the same dimensions in order to withstand the highest pressures and achieve maximum bale density.

- The baler rollers are driven by 1 1/4 inch high performance roller chains.
- Automatic chain tensioner with display.
- Automatic chain lubrication.
- Multiple-tooth profile reliably transmits power to the starter and compression rollers.
- Heavy duty self-aligning bearings with a diameter of 1.97 in / 50 mm.

Variable round balers



IMPRESS 155 V / 185 V

IMPRESS 155 V / 185 V MASTER

Chopping system with 16 knives,
PTO speed 540 rpm,
Pick-up width 6.73 ft / 2.05 m, optional 7.55 ft / 2.30 m,
SELECT CONTROL operator terminal.

IMPRESS 155 V / 185 V PRO

Chopping system with 32 knives,
PTO speed 1000 rpm,
Pick-up width 7.55 ft / 2.30 m,
POWER CONTROL operator terminal,
optional EXPERT 75 / EXPERT 100.



Variable round balers



IMPRESS 155 V / 185 V



IMPRESS 155 V

Bale width 3.94 ft / 1.20 m, bale diameter 2.62 to 5.09 ft / 0.80 to 1.55 m.

IMPRESS 185 V

Bale width 3.94 ft / 1.20 m, bale diameter 2.95 to 6.07 ft / 0.90 to 1.85 m.

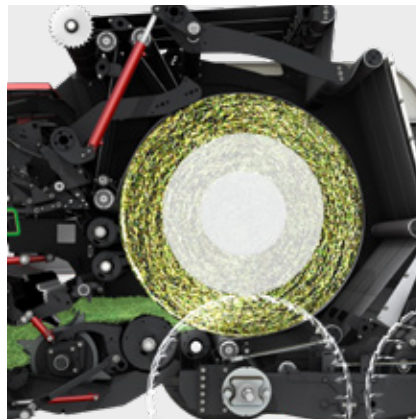

Convenient operation from the tractor seat

The bale density can be variably set using the baling pressure and adjusted to the properties of the material to be baled.

Three endless belts

The variable chamber models have three endless belts with a hydraulically-adjustable pressure-controlled belt tensioner. The three endless belts make sure the bale rotates in every situation, even with straw.

- Multi spline profile for reliable power transmission to the starter rollers.
- The belt rollers have a cleaning roller to prevent material from building up on the roller.

3-zone soft core control is standard

The belt tensioner makes it possible to control variable compression for the bale core, middle zone and outer zone. The size of the zones and the chosen zone pressures can be set using the terminal.

This makes it possible to produce an extremely wide range of highly stable bales of different diameter. Either with soft or medium-compact cores, compact or soft middle zones and high density outer zones.

- Hydraulic tailgate, infinitely variable bale diameter.
- Six pre-select parameters on PRO models for hay/straw/silage.

Baler & wrapper combinations



IMPRESS FC / VC

Bale and wrap in one pass

IMPRESS 125 FC PRO / 155 VC PRO

Chopping system with 32 knives,
PTO speed 1000 rpm,
Pick-up width 7.55 ft / 2.30 m,
POWER CONTROL operator terminal,
optional EXPERT 75 / EXPERT 100,
Tandem axle with 520/55 R 22.5 tyres.



Baler & wrapper combinations



Engineered for professionals

IMPRESS 125 FC PRO / 155 VC PRO

Bale width 3.94 ft / 1.20 m,

Bale diameter 125 FC PRO 4.26 – 4.43 ft / 1.30 – 1.35 m,

Bale diameter 155 VC PRO 2.62 to 5.09 ft / 0.80 to 1.55 m,

Wrapping diameter 3.61 – 4.92 ft / 1.10 – 1.50 m.

Designed for the highest reliability and output.

Direct wrapping, continuous loading and double bale placing. An innovative, fast, high throughput wrapper to match the high output baler. Adjustable wrapping satellites for bale diameters between 3.61 – 4.92 ft / 1.10 – 1.50 m (155 VC).



Best forage quality

Bale and wrap in one pass

The best forage quality thanks to finished bale being wrapped immediately.



Reliability

- Compact wrapper unit with double wrapper arms underneath.
- Wrap pre-stretch unit with wrap break monitor easily adjusted to 50% or 70% pre-stretch.
- Rapid and reliable bale transfer on slopes up to 40% with linear transfer unit onto the wrapper table.
- Wrap storage on both sides concealed behind body panels.
- Wrap break monitor.
- Emergency switch for wrapper complies with the latest safety regulations.
- High ground clearance under front of pick-up and at back end of the wrapper.

IMPRESS FC / VC



Direct wrapping

Fully automatic adjustable wrapping system that operates at high working speeds. Bale is already close to ground and as such the risk of damaging film is greatly reduced.

Convenience

- Choose between automatic and manual mode.
- Convenient controls at the rear for maintenance and service work.
- Hydraulic folding wrap storage protected inside bodywork.
- LED floodlights, flashing beacon and camera system as standard.



Easy service

- Centralised progressive greasing of the bale chamber roller bearings.
- Automatic greasing system optional.



Intelligent control



SELECT CONTROL – Electronic preselect functions

on MASTER models.

- Functions can be preselected using the terminal.
- High quality 2-component casing with display and status indicator.
- Raised back-lit keys offer optimum visibility at night.
- Operator terminal with magnetic mounting.
- Total bale counter and daily bale counter.
- Flexible soft core setting in 3 zones.
- Acoustic signal before baling starts.
- Acoustic signal when bale is finished.
- Displays belt tension (V), forming pressure (F), diameter, number of net layers.
- Driving direction display.
- Automatic operating modes: Automatic knotting system.
- Status symbols for pick-up, knives, chopping floor and net wrapping.
- Setting of bale diameter, net layers and forming pressure.

Connections:

- 1 x 3-pin Cobo plug.
- 2 x double acting, 1 x free flow return.
- Oil filter as standard.



POWER CONTROL – Electronic control system

Standard on IMPRESS PRO models.

- Functions can be controlled directly from the terminal.
- High quality 2-component casing with display and status indicator.
- 4 function keys for convenient operation of additional equipment.
- Raised back-lit keys offer optimum visibility at night.
- Diagnostics system: Displays error messages.
- Operator terminal with suction mounting.
- Total bale counter and 3 separate customer counters.
- Flexible soft core setting in 3 zones.
- Acoustic signal before baling starts.
- Acoustic signal when bale is finished.
- Displays belt tension (V), forming pressure (F), diameter, number of net layers.
- Status symbols for pick-up, knives, chopping floor, net wrap and automatic greasing system (optional).
- Driving direction display.
- Automatic operating modes: Automatic knotting system, automatic tailgate (bale kicker required) and automatic pick-up lift.
- Semi-automatic function with play / pause for all automatic modes – unique feature.
- Setting of bale diameter, net layers and forming pressure.

Connections:

- 1 x 3-pin Cobo plug.
- 1 x single acting, 1 x free flow return.
- 1 x load sensing.
- Oil filter as standard.

DIGITAL AGRICULTURAL TECHNOLOGY



EXPERT 75

ISOBUS optional on IMPRESS PRO models.

ISOBUS is the worldwide standard for the communication between tractors and machinery, as well as the transfer of data between these mobile systems and agricultural office software. The PÖTTINGER EXPERT ISOBUS terminals enable professional operation of all ISOBUS-compatible machines, regardless of brand.

- Convenient single-hand operation, grip bar for secure hold.
- Double-row arrangement of 12 soft keys (F1-F12) on the right.
- Edit using keys and touch-screen.
- Scroll wheel with confirmation function for direct input and adjustment of set points.
- Rugged synthetic casing, compact dimensions.
- High quality 5.6" TFT colour touch-screen.
- Ambient light sensor and back-lit function keys.
- Total bale counter and 20 separate customer counters.
- USB interface for screen shots and terminal programmer extension.
- AUX joystick compatible.
- Scroll wheel with confirmation function for direct input and adjustment of set points.
- Extended ISOBUS functions: ISO automatic binding (speed signal required via signal socket).



EXPERT 100 – CCI 100

ISOBUS optional on IMPRESS PRO models.

- Rugged synthetic casing.
- High quality 8.4" TFT colour touch-screen.
- Six soft keys on left and right (F1-F12)
- Ambient light sensor and back-lit function keys.
- Total bale counter and 20 separate customer counters.
- USB interface for screen shots and terminal programmer extension.
- Video input for M12x1 camera.
- AUX joystick compatible.
- Scroll wheel with confirmation function for direct input and adjustment of set points.
- Extended ISOBUS functions: ISO automatic binding (speed signal required via signal socket).

IMPRESS PRO baler & wrapper combinations

POWER CONTROL / EXPERT 75 / EXPERT 100

- All functions can be controlled directly from the terminal.

Accessories

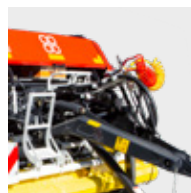
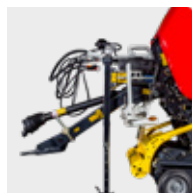
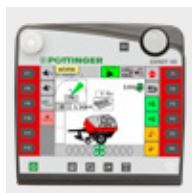
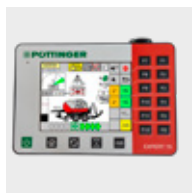

EXPERT 75
ISOBUS

EXPERT 100
CCI 100 ISOBUS

Low drawbar

**Hydraulic pivoting
drawbar**

Bale kicker

IMPRESS MASTER	-	-	<input type="checkbox"/>	-	<input type="checkbox"/>
IMPRESS PRO	<input type="checkbox"/>	<input type="checkbox"/>	<input type="checkbox"/>	<input type="checkbox"/>	<input type="checkbox"/>
IMPRESS FC / VC PRO	<input type="checkbox"/>	<input type="checkbox"/>	<input type="checkbox"/>	<input type="checkbox"/>	-



**Low drawbar with ball
hitch**

**Towing eye / towing
eye extension
+ 2.75 in / 70 mm**

**Pick-up
7.55 ft / 2.30 m**

**Hydraulic
Brake**

**Tyres
500/50-17**

IMPRESS MASTER	<input type="checkbox"/>	<input type="checkbox"/>	<input type="checkbox"/>	<input type="checkbox"/>	<input type="checkbox"/>
IMPRESS PRO	<input type="checkbox"/>	<input type="checkbox"/>	■	<input type="checkbox"/>	■
IMPRESS FC / VC PRO	<input type="checkbox"/>	<input type="checkbox"/>	■	<input type="checkbox"/>	-

■ = Standard, □ = Optional

Often ordered together.

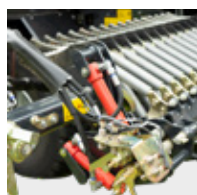
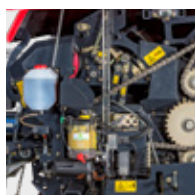

Automatic greasing system

Individual TWINBLADE knives

Hydraulic knife pre-selection

Camera / monitor

Tandem axle

Flashing beacon

-	■	-	□/□	□	□
□	■	□	□/□	□	□
□	■	□	■/□	■	■

Tyres 520/50 R 17

Tyres 500/60 R 22.5

Tyres 520/55 R 22.5

Tyres 620/40 R 22.5

Load sensing kit (recommended)

□	□	□	□	-
□	□	□	□	□
-	□	■	-	■

Technical data



Fixed chamber round balers	Bale diameter ft / m	Power requirement from	Pick-up width ft / m	Operation	Knife – knife spacing inch / mm
IMPRESS 125 F MASTER	4.26 – 4.43 / 1.30 – 1.35	59 kW / 80 hp	6.73 / 2.05	SELECT CONTROL	16 – 2.83 / 72
IMPRESS 125 F PRO	4.26 – 4.43 / 1.30 – 1.35	74 kW / 100 hp	7.55 / 2.30	POWER CONTROL	32 – 1.42 / 36



Variable chamber round balers

IMPRESS 155 V MASTER	2.62 to 5.09 / 0.80 to 1.55	59 kW / 80 hp	6.73 / 2.05	SELECT CONTROL	16 – 2.83 / 72
IMPRESS 155 V PRO	2.62 to 5.09 / 0.80 to 1.55	74 kW / 100 hp	7.55 / 2.30	POWER CONTROL	32 – 1.42 / 36
IMPRESS 185 V MASTER	2.95 to 6.07 / 0.90 to 1.85	59 kW / 80 hp	6.73 / 2.05	SELECT CONTROL	16 – 2.83 / 72
IMPRESS 185 V PRO	2.95 to 6.07 / 0.90 to 1.85	74 kW / 100 hp	7.55 / 2.30	POWER CONTROL	32 – 1.42 / 36



Baler & wrapper combinations	Bale diameter ft / m	Wrapper diameter ft / m	Power requirement from	Pick-up width ft / m	Hydraulic power required
IMPRESS 125 FC PRO	4.26 – 4.43 / 1.30 – 1.35	4.26 / 1.30	96 kW / 130 hp	7.55 / 2.30	60 l/min, 180 bar
IMPRESS 155 VC PRO	2.62 – 5.09 / 0.80 – 1.55	1.10 – 1.50	96 kW / 130 hp	7.55 / 2.30	60 l/min, 180 bar

Tractor PTO speed	Length ft / m	Outside width ft / m	Height ft / m	Tyres Standard	Weight lbs / kg
540 rpm	15.28 / 4.657	8.60 / 2.620	8.35 / 2.545	380/55-17	10472 / 4750
1000 rpm	15.28 / 4.657	9.28 / 2.830	8.35 / 2.545	500/50-17	10692 / 4850

540 rpm	16.07 / 4.897	8.60 / 2.620	9.27 / 2.825	380/55-17	10472 / 4750
1000 rpm	16.07 / 4.897	9.28 / 2.830	9.27 / 2.825	500/50-17	10692 / 4850
540 rpm	16.76 / 5.107	8.60 / 2.620	10.17 / 3.100	380/55-17	10692 / 4850
1000 rpm	16.76 / 5.107	9.28 / 2.830	10.17 / 3.100	500/50-17	10913 / 4950

Twin wrapper satellites	Length ft / m	Outside width ft / m	Height ft / m	Tyres Standard	Weight lbs / kg
36 rpm	23.75 / 7.240	9.48 / 2.890	8.37 / 2.550	520/55 R 22.5	16623 / 7540
36 rpm	23.75 / 7.240	9.48 / 2.890	9.27 / 2.825	520/55 R 22.5	16623 / 7540

PÖTPRO



Scan the QR Code on the data plate of a PÖTTINGER machine or enter the machine number at www.poettinger.at/poetpro.

Choose the information you need.

PÖTPRO – Simple. Anytime. Anywhere.

For all PÖTTINGER machines 1997 models onwards

PÖTPRO stands for PÖTtinger PROduct information for Pöttinger Professionals. We have created PÖTPRO as a tool to provide machine-specific information for all machines from year of build 1997 onwards.

Simply scan the QR code on the data plate with your smartphone or tablet or enter your machine number at www.poettinger.at/poetpro.

Your machine goes online.

All the information on your machine.

You will immediately receive all the information on your machine.

- Instruction manual
- Optional equipment information
- Brochures
- Photos and videos.

ORIGINAL PARTS



CLASSIC

DURASTAR

DURASTAR PLUS

Rely on the original

PÖTTINGER Original Parts meet the highest demands in terms of functionality, reliability and performance. These are characteristics that PÖTTINGER is committed to delivering.

That is why we manufacture PÖTTINGER Original Parts from the highest quality materials. We ideally match each individual spare part and wear part to your machinery's overall system. This is because different soil and operating conditions often need to be taken into consideration.

We have been listening to our customers and now offer three different lines - CLASSIC, DURASTAR and DURASTAR PLUS - to make sure you have the right part to meet every requirement. Original parts are worth every cent, because know-how cannot be copied.

Your advantages

- Immediate and long-term availability.
- Maximum durability thanks to innovative production processes and the use of the highest quality materials.
- Avoidance of malfunctions due to a perfect fit.
- The best working results thanks to optimum match to the overall system of the machine.
- Save time and costs thanks to longer replacement intervals on wear parts.
- Comprehensive quality testing.
- Ongoing advancement through research and development.
- Worldwide spare parts supply.
- Attractive, competitive prices for all spare parts.

Wear parts

The CLASSIC line is for standard duty applications. With these ORIGINAL INSIDE parts we have defined the benchmark for quality, best price/performance ratio and reliability.

DURASTAR is the innovation on the wear components market - durable, high quality, productive and reliable.

Are you used to putting your machines to work in the most extreme conditions? Then the DURASTAR PLUS line is the right choice for you.



More Success with PÖTTINGER

- A family-owned company since 1871. Your reliable partner.
- Specialist for tillage, seed drills, hay and harvesting machines.
- Future-safe innovation for outstanding working results.
- Roots in Austria - at home throughout the world.

Harvest quality

- Healthy soil is one of the key provisions for optimising your yield. We support you in achieving this with our machines.
- Clean, tasty base forage is the foundation for an efficient dairy business. From mowing through to harvesting, we help you have a positive influence on the quality of your forage.
- Trust in PÖTTINGER. Harvest success.

Ask our sales partners for more information:

PÖTTINGER Landtechnik GmbH

Industriegelände 1
4710 Grieskirchen
Austria
Phone +43 7248 600-0
info@poettinger.at
www.poettinger.at

Alois PÖTTINGER UK Ltd.

15 St Marks Road, Corby
Northamptonshire,
NN18 8AN
United Kingdom
Phone + 44 1536 272 220
info@pottingeruk.co.uk
www.pottingeruk.co.uk

POETTINGER Canada Inc.

460 Rue Robinson Sud
Granby, QC, J2G 7N6
Canada
Phone +1 450 372 5595
Fax +1 866 417 1683
info@poettinger.ca
www.poettinger.ca

POETTINGER US, Inc.

393 Pilot Drive
Valparaiso, IN 46383
USA
Phone +1 219 510 5534
Fax + 1 219 707 5412
info@poettinger.us
www.poettinger.us

PÖTTINGER Australia PTY LTD

11 Efficient Drive
Truganina VIC 3029
Australia
Phone +61 3 8353 2770
info@poettinger.com.au
www.poettinger.com.au

POETTINGER Ireland Ltd.

Glenaleamy, Powerstown Road,
Clonmel, Co. Tipperary
Ireland
Phone +353 52 6125766
info@poettinger.ie
www.poettinger.ie

Importer for New Zealand:

Origin Agroup
PO Box 673, 57 Hautapu Road
Cambridge
New Zealand
Phone +64 7 823 7582
info@originagroup.co.nz
www.originagroup.co.nz

Importer for South Africa:

VALTRAC
Cnr. Water & Buiten Street
9585 Parys
South Africa
Phone +27 56 817 7338 7308
wynn@valtrac.co.za
www.valtrac.co.za