

Product range for hay, forage, tillage and seeding equipment



More Success with PÖTTINGER



PÖTTINGER product range

Table of contents

Tillage and Seeding	06-47
Best soil	06
Ploughs	08
Stubble cultivators	12
Compact combinations	16
Disc harrows	20
MULTILINE concept	24
Cover crop sowing unit	26
Power harrows	28
Mechanical seed drills	34
Pneumatic seed drills	38
Mulch seed drills	42
Hay and Forage	48-81
Best forage	48
Mowers	50
Tedders	58
Rakes	62
Loader wagons	66
Round balers	72
Other topics	78-84
Control terminals	78
PÖTPRO	81
PÖTTINGER Original Parts	82
Technology and Innovation Centre	84

How to find our online questionnaire:

- Tillage
- Grassland
- Other topics

All information on technical data, dimensions, weights, output, etc. and the images shown, are approximate and are not binding. The machines shown do not feature country-specific equipment and may include equipment that is not supplied as standard, or is not available in all regions. Your PÖTTINGER dealership would be pleased to provide you with more information.

A company based on tradition and progress



PÖTTINGER Grieskirchen (AT)

More Success with PÖTTINGER

This motto is a promise to our customers. With the outstanding working results of our machines and services we will ensure that as one of our customers you are more successful. Our objective is to make your work easier and enable sustainable operations.

As a family-owned business with a long tradition, we have a great deal of international experience. We offer a very wide range of products in order to provide the best solutions for very different living and working conditions. Our product range is as varied as the needs of our customers:

Following our powerful claim for the best soil, we have developed intelligent systems and machines for tillage. Business success is closely associated with the best forage. Grassland harvesting machines that are perfectly matched to one another make a valuable contribution here.

With the PÖTTINGER product range for soil, seed and grassland, we cover your requirements perfectly.

Jörg Lechner

Markus Baldinger

Herbert Wagner

Wolfgang Moser

Gregor Dietachmayr



PÖTTINGER Vodňany (CZ)



PÖTTINGER Bernburg (DE)

Milestones in the company's history

- 1871** Company founded by Franz Pöttinger in Grieskirchen (AT) - grassland machines.
- 1941** Production capacity increased through the acquisition of the Grieskirchen foundry.
- 1960** New factor built in Grieskirchen (AUT), today's headquarters.
- 1975** Entering the tillage industry with the takeover of the Bavarian plough factory in Landsberg / Lech (GER).
- 2001** Acquired seed drill technology plant in Bernburg (GER).
- 2007** Built plant in Vodnany (CZE) as the competence centre for tillage machines.
- 2017** Spare parts logistics centre in Taufkirchen/Tr. (AT) goes into operation.
- 2018** New assembly line and logistics workshops open in Grieskirchen (AUT).

Best soil



The soil is the basis for agriculture and forestry and is one of the world's most important yet limited resources. Soils are the essence of our life since they provide the basis for nutrition for us and our livestock. Healthy soil is one of the key provisions for optimising your yield.

Ploughs – perfect incorporation

Tillage with the plough achieves a clean arable surface that is free of residual materials. Turning the soil also incorporates fertiliser, harvest residues and plants. Ploughing arable land makes an important contribution to weed control and fighting pests and disease.

Stubble cultivators – breathing life into the soil

The incorporation of harvest residues near the surface increases the fertility of the soil and protects against erosion. The capillary effect is interrupted by the stubble cultivator to retain moisture. Our SYNKRO stubble cultivators are available in two and three-row versions. The versatile rear rollers create ideal germination conditions for weeks and volunteers.

Disc harrows – revitalising the soil

The TERRADISC compact disc harrow is designed specifically for stubble cultivation and seedbed preparation. Its compact construction and aggressive wheel position ensure a perfect collection and good mixing of harvest residues.

PÖTTINGER tillage & seed drill technology



Power harrows – thorough soil preparation

The best tilth, excellent mixing and levelling are the basis for successful planting. A power harrow working together with a seed drill is a high output and cost-effective combination delivering perfect sowing results. PÖTTINGER offers you tailor-made systems for every type of soil and every size of operation.

Compact combinations – fine tilth seedbed

Our FOX compact combinations are available with harrow tines and the FOX D with discs. With our compact combinations you benefit from low draft, fuel-saving seedbed preparation. Combined with a PÖTTINGER seed drill, this implement becomes a cost-effective seed drill combination.



Mechanical seed drills – uniform seed placement

Our seed drills meet the highest demands in functionality, reliability and performance. Unique metering systems, uniform seed placement and convenient operation are among the trademarks of our mechanical seed drills.

Pneumatic seed drills – precision operation

Our pneumatic seed drills for cereals and maize (single-seed placement). The unique AEROSEM seed drill concept unites the drilling of cereals and maize. Precision universal metering and perfect coulter systems guarantee exact placement of the seed.



Mulch seed drills – perfect sowing

Our TERRASEM mulch drilling concept combines soil preparation, consolidation and drilling in a single machine. The effective compact disc harrow or low disturbance WAVE DISC, the unique tyre packer and the perfect coulters ensure an optimum working result.

Perfect incorporation



The heavy-duty and intelligent design of PÖTTINGER ploughs ensures optimum distribution of force and strength at the points of the plough beam subject to the highest stress. The unique PÖTTINGER control centre lets you easily adapt the plough perfectly to all types of soil and the current operating conditions.



NONSTOP protection against stones

- No digging or loosening of big rocks. This protects the whole plough.
- On triggering, the pressure gradually reduces to ensure reliable penetration in heavy, dry soil.
- Set the trigger point quickly and easily using the pressure gauge on the headstock.



Easy adjustment

- With SERVOMATIC setting technology, you can quickly and easily adjust the plough to the tractor and soil conditions.
- Straightforward yet ingenious plough set-up.
 - Saves time with flexible mounting for modern tractor geometries.
 - For perfect working results.



That helps you save fuel.

TRACTION CONTROL is available as an option on SERVO 45 M / 45 S and 6.50 models to provide defined loading of the tractor rear axle. Wheel slips is reduced by perfectly matching the pulling force and load on the rear axle. As a result, this enables maximum performance on the part of the tractor. This saves up 0.22 gal/acre / 2.1 l/ha and conserves the soil.

Assessment of the influence of TRACTION CONTROL on fuel consumption and wheel slip

Performance and consumption data for medium-heavy soil, working width 2.60 m, working depth 25 cm

Driving strategy	without TRACTION CONTROL	with TRACTION CONTROL	Efficiency
Performance	4.79 acres/h / 1.94 ha/h	5.12 acres/h / 2.07 ha/h	+ 0.32 acres/h / 0.13 ha/h
Diesel consumption	2,16 gal/acre > 20,5L/ha	1,94 gal/acre > 18, 4 L/ha	-0,22 gal/acre > -2,1 l/ha
Diesel consumption	10,48 gal/acre > 39,7 l/ha	10,04 gal/acre > 38 l/ha	-0,66 gal/acre > -1,7 l/ha
Wheel slip	4.8 %	3.3 %	- 1.5 %

Markus Schüller, Gerhard Moitzi, Institute for agricultural technology at the Soil Sciences University in Vienna
 Helmut Wagenristl, Pilot Farm in Groß Enzersdorf, Soil Sciences University in Vienna



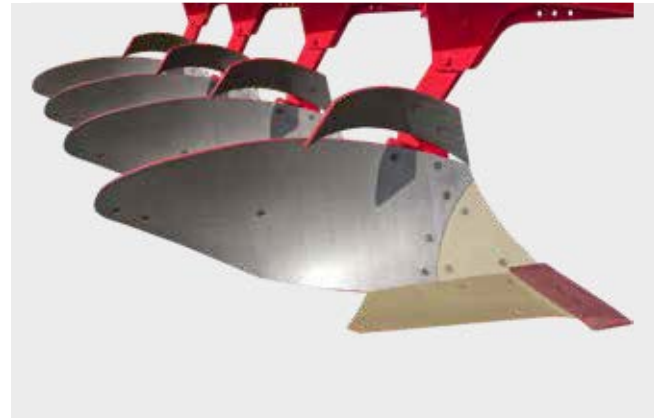

Durable

- Maximum plough beam strength at the point of maximum bending stress.
- The inner web increases resistance to flexing by up to 25 %.
- Best power distribution and strength thanks to full-length plough beam reinforcement.

For all operating conditions

- Slatted mouldboards in hardened, fine-grained boron steel.
- Four way reversible share blades.
- Synthetic plough bodies for soils with low stability.
- For every type of soil - we have the right mouldboards for the best working result.

Overview of plough models



SERVO 6.50 – semi-mounted ploughs

High output semi-mounted reversible ploughs that can be optimally adapted to match various tractor tyre configurations – for tractors up to 360 hp.

	Furrows	Inter-body spacing inch / mm	For tractors up to
SERVO 6.50 PLUS NOVA	6 / 7 / 8	37.4 / 1020	265 kW / 360 HP



SERVO PLUS NOVA – the hydraulic multi-talent

Ploughs with hydraulic furrow width adjustment and hydraulic trip leg system offer you maximum reliability and flexibility.

	Furrows	Inter-body spacing inch / mm	For tractors up to
SERVO 35 PLUS NOVA	3 / 4	34.6/37.4/40.2 / 880/950/1020	103 kW / 140 HP
SERVO 35 S PLUS NOVA	4 / 5	37.4/40.2 / 950/1020	125 kW / 170 HP
SERVO 45 M PLUS NOVA	4 / 5	37.4/40.2 / 950/1020	176 kW / 240 HP
SERVO 45 S PLUS NOVA	4 / 5 / 6	37.4/40.2 / 950/1020	257 kW / 350 HP

Airing the soil



The PÖTTINGER SYNKRO cultivators have been developed to deliver optimum stubble cultivation, and are suitable for both shallow and deep tillage. During the design phase, special attention was paid to low drag resistance and low power requirement.



Proven on all types of soil

The SYNKRO 1030 series available with a combination of points and wing shares. The narrow tine spacing of 10 3/4 inc ensures optimum incorporation of harvest residues. The ideal tool for mulch drilling. For deeper tillage, you can choose between a narrow point, a double diamond point or a chisel point.

Stubble cultivator



NONSTOP protection against stones

On the SYNKRO NOVA, spring-mounted tines guarantee NONSTOP cultivation in stony soil.

- The levelling discs also feature stone protection.
- The triggering force of 1212 lbs / 550 kg diminishes as the leg is raised – stones are not pulled up or loosened.
- Tine positions for reliable ground penetration even in the hardest conditions.

- Additional shear bolt prevents fractures.
- Coating even withstands stone impact.

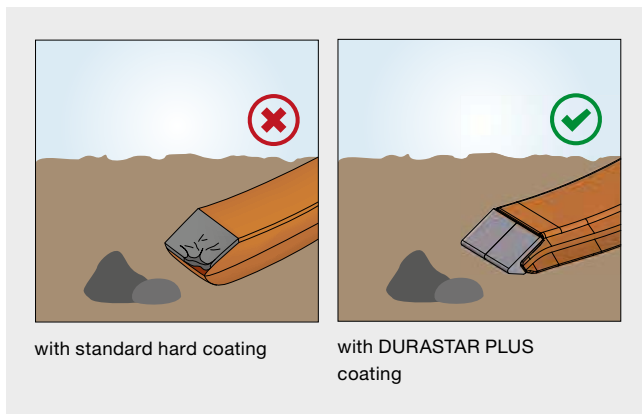

Extended service life

- High quality steel and hardened metal for the points.
- Much longer service life and higher resistance to fracture for top reliability.
- The service life is up to 6 times longer than with standard points.
- Improved penetration, lower power required thanks to optimised shins.
- Optimum loosening and mixing through of soil.

Airing the soil



Stubble cultivator

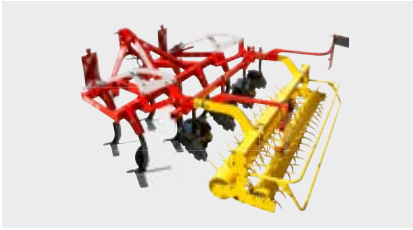

SYNKRO – two-row mounted stubble cultivators

PÖTTINGER SYNKRO stubble cultivators have been developed to deliver optimum stubble cultivation. Our compact two-row series operates smoothly at a low power requirement. An underframe clearance of 31.49 inch / 80 cm guarantees you trouble-free operation.

	Working width ft / m	Tines	Tine spacing inch / cm	Power requirement from
SYNKRO 2520 NOVA	8.20 / 2.5	6	16.73 / 42,5	51 kW / 70 hp
SYNKRO 3020 NOVA	9.84 / 3.0	7	16,53 / 42	66 kW / 90 hp



SYNKRO – three-row mounted stubble cultivators

You can use our SYNKRO three-gang stubble cultivators for shallow and deep tillage. A central adjustment system allows you to adjust the working depth quickly and easily.

	Working width ft / m	Tines	Tine spacing inch / mm	Power requirement from
SYNKRO 3030 NOVA	9.84 / 3.0	11	10.60 / 270	80 kW / 110 HP
SYNKRO 3530 NOVA	11.48 / 3.5	12	11,22 / 285	96 kW / 130 HP
SYNKRO 4030 K NOVA	13.12 / 4.0	14	11.02 / 280	110 kW / 150 HP
SYNKRO 5030 K NOVA	16.40 / 5.0	18	11.02 / 280	132 kW / 180 HP



SYNKRO T - three-row trailed stubble cultivators

Trailed stubble cultivator with transport chassis. The weight acting on the hitch is reduced and your tractor is protected. The transport chassis is raised during operation in the field. In the raised position, it applies additional pressure to the tillage tools.

	Working width ft / m	Tines	Tine spacing inch / mm	Power requirement from
SYNKRO 4030 T NOVA	13.12 / 4.0	14	11.02 / 280	110 kW / 150 HP
SYNKRO 5030 T NOVA	16.40 / 5.0	18	11.02 / 280	132 kW / 180 HP
SYNKRO 6030 T NOVA	19.68 / 6.0	22	10.60 / 270	155 kW / 210 HP

K = folding, T = trailed, folding

Clever seedbed preparation



Our FOX and FOX D compact combinations deliver smooth-running, fuel-saving seedbed preparation. Combined with a PÖTTINGER seed drill, this implement becomes a cost-effective seed drill combination.



FOX D discs

- With the FOX D the discs take over the preparation of the soil. The discs are mounted on rubber elements that provide a degree of vertical travel and are suitable for slightly stony soil.
- The discs have a diameter of 161 inch / 410 mm and are fitted with sealed bearings.

Compact combination



Focussing on cost effectiveness

During the development of the PÖTTINGER compact combinations, great attention was paid to compact dimensions and low draft.

Highest flexibility

- Combined with a PÖTTINGER seed drill, this implement becomes a cost-effective 3-point-mounted seed drill combination.
- Solo for incorporating harvest residues into the soil.
- The drill is mounted either on the packer roller or using HYDROLIFT.
- Combinable with linkage-mounted VITASEM, implement-mounted VITASEM and AEROSEM.



Convenient to use

- The short headstock has lugs for the lower linkages mounted on bars that can be slid into three different positions.
- In addition, two different top link positions make it easy to connect up and adapt to any tractor.

Low draft

- Lets you use smaller tractors for fuel-saving and efficient seedbed preparation.

Clever seedbed preparation



Compact combination



The ideal machine for mulch drilling.

This lightweight linkage-mounted machine is ideal for use in light to medium soils with low levels of harvest residues. Combined with a seed drill, the FOX compact combination demonstrates yet another talent. The result is a cost-effective mulch drilling combination.

Best working results guaranteed

The trademark of our FOX compact combinations equipped with harrow tines or discs is their compact construction. You can also achieve high working speeds with these drill combinations. The FOX D disc version is the right choice if organic matter also needs to be incorporated.



Rear rollers – it's your choice

PÖTTINGER offers a wide range of rear rollers for perfect results with the desired tilth in any type of soil. The whole range of rollers features precision manufacturing and robust design engineering. Straightforward, central adjustment of all scrapers as standard equipment.



	Working & transport width ft / m	Discs	Attachment spacing inch / mm	Working depth inch / mm	Power requirement from
FOX 300 D	9.84 / 3.0	22	5.11 / 130	1.18 – 3.14 / 30 – 80	55 kW / 75 HP
FOX 400 D	13.12 / 4.0	30	5.11 / 130	1.18 – 3.14 / 30 – 80	74 kW / 100 HP

Revitalising the soil



The TERRADISC compact disc harrow is designed specifically for stubble cultivation and seedbed preparation. The compact design and aggressive disc angle ensure reliable penetration and excellent mixing in of harvest residues.

- 1 Perfect entry thanks to aggressive disc angle
- 2 Blockage-free operation thanks to large clearances
- 3 Extended service life with tempered and forged parts
- 4 Worked soil – uniform and level finish following consistent movement
- 5 Unworked soil

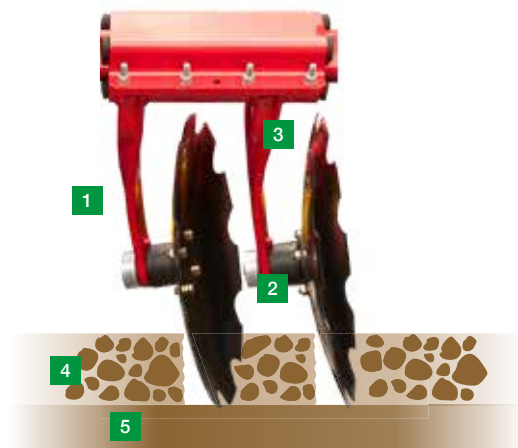

Intensive mixing

The proven PÖTTINGER TWIN ARM system: two solid forged carrier arms are welded to a very wide clamping bracket. This ensures that the discs always retain their position and angle.

A uniform and level finish is achieved for both shallow as well as deep tillage. Perfect soil penetration is guaranteed. Intensive mixing of the soil takes place reliably even in hard, dry conditions with high levels of harvest residues.



TERRADISC – rigid compact disc harrows

The short construction is a key feature of PÖTTINGER compact disc harrows. Working depths between 1.18 and 4.72 inch / 3 and 12 cm are possible. The offset configuration of the aggressively set discs mixes the harvest residues effectively into the soil.

	Working width ft / m	Discs	Disc diameter inch / mm	Power requirement from
TERRADISC 3001	9.84 / 3.0	24	22.83 / 580	70 kW / 95 HP
TERRADISC 3501	11.49 / 3.5	28	22.83 / 580	85 kW / 115 HP
TERRADISC 4001	13.1 / 4.0	32	22.83 / 580	100 kW / 135 HP



TERRADISC K / T – folding / trailed compact disc harrows

TERRADISC K – with a working width of 13.12 to 19.68 ft / 4 to 6 m and increased manoeuvrability thanks to three-point linkage mounting. TERRADISC T harrows are transported on a dedicated chassis.

	Working width ft / m	Discs	Disc diameter inch / mm	Power requirement from
TERRADISC 4001 T	13.12 / 4.0	32	22.83 / 580	100 kW / 135 HP
TERRADISC 5001 T	16.40 / 5.0	40	22.83 / 580	125 kW / 170 HP
TERRADISC 6001 T	19.69 / 6.0	48	22.83 / 580	140 kW / 190 HP



TERRADISC T – trailed compact disc harrow

TERRADISC T – with a working width of 26 ft to 32 ft / 8 to 10 m. TERRADISC T models are transported on a dedicated chassis. This protects your tractor hydraulics and reduces compaction at the headland.

	Working width ft / m	Discs	Disc diameter inch / mm	Power requirement from
TERRADISC 8001 T	26.25 / 8.0	64	22.83 / 580	198 kW / 270 HP
TERRADISC 10001 T	32.81 / 10.0	80	22.83 / 580	265 kW / 360 HP

Rear rollers

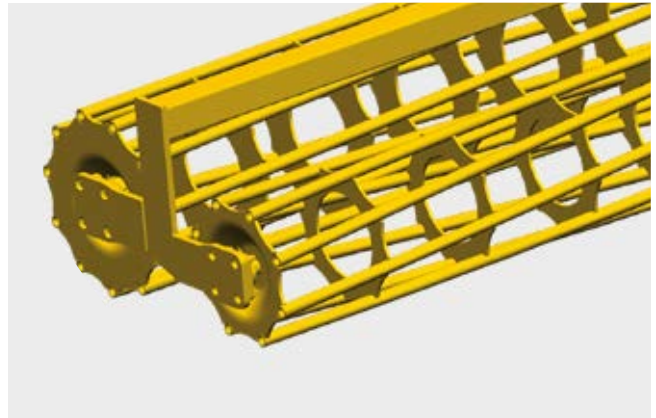
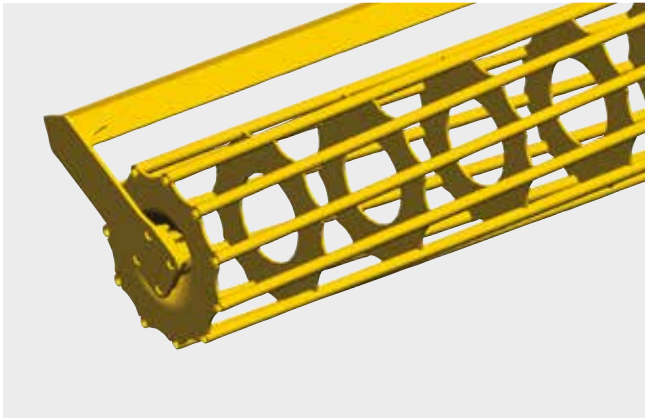

Cage roller

The cage roller is the ideal rear roller for handling dry, non-sticky soils. The roller is fitted with strong rods for optimal re-consolidation.

Double cage roller

Thanks to its freedom of movement, the double cage roller has the ground tracking necessary to deliver optimum quality tilth.

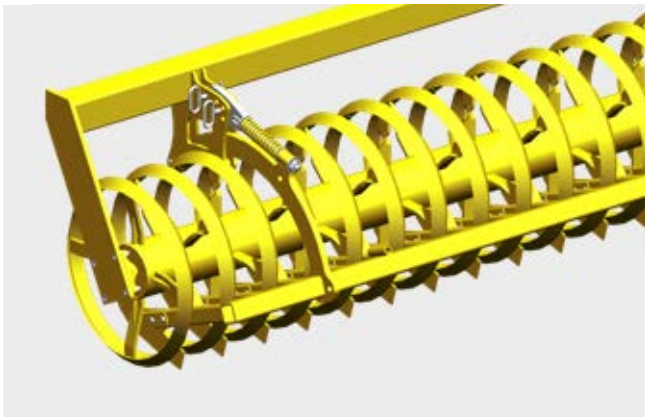

Knife ring roller

The knife ring roller creates consolidated ridges. This allows water to be absorbed better. The right choice if you are working on dry and heavy soil.

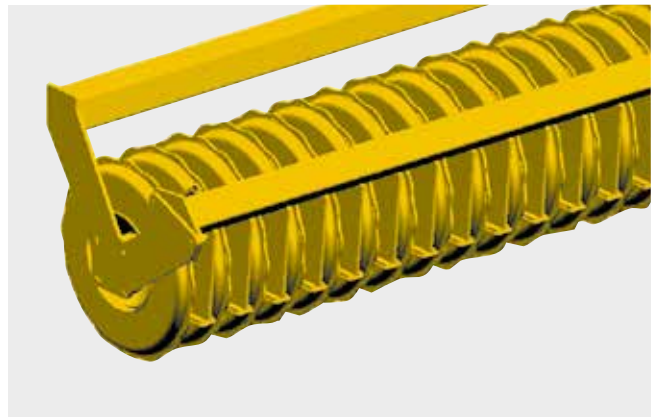

Pack ring roller

The roller leaves behind consolidated ridges, promoting drainage and soil respiration. The perfect roller for stony and damp soil.

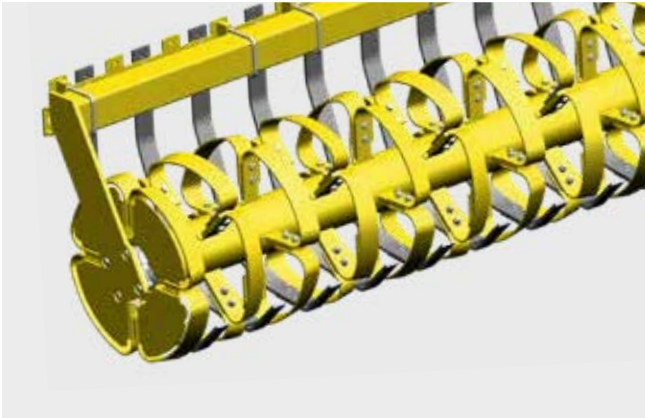

CONOROLL roller

Thanks to the shape of the CONOROLL, rain water seeps into the soil profile created by the roller. The water does not run off unchecked. This is an ideal roller for medium to heavy soils.

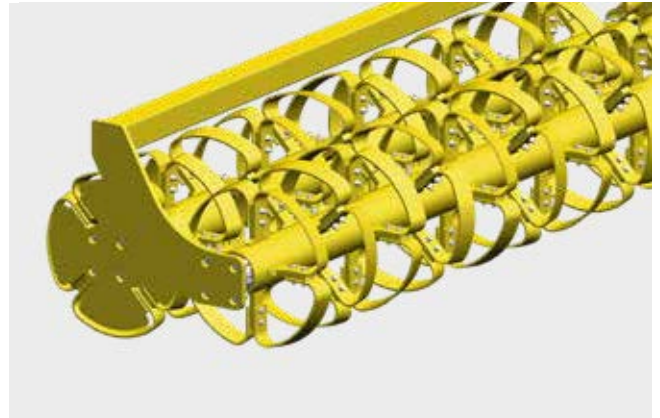

TANDEM CONOROLL roller

With two rollers the TANDEM CONOROLL offers excellent load capacity. Consequently it is also suitable for light soils. Trouble-free operation is also guaranteed in stony soil.



Rubber packer roller

The perfect roller for widely varied soil conditions. Especially for operation with trailed implements with a high load capacity. The special profile produces consolidated ridges.

The multi-role arable combination



From stubble cultivation to mulch drilling with implement-mounted VITASEM ADD or AEROSEM ADD seed drills. Within just a few minutes, the trailed TERRADISC disc harrow becomes an efficient, fully-functional mulch seed drill.



Working cost-effectively

The MULTILINE is a trailed implement. As a result, less weight acts on the rear axle of the tractor, enabling high output to be achieved even with smaller tractors.



Stability during transport

At the headland and during transport, the TERRADISC MULTILINE is lifted by the tyre packer so the weight is distributed over the whole working width. The tyre packer also ensures excellent stability on the road.

MULTILINE concept



Hitching up made easy

Drawbar connects to lower linkage.

The MULTILINE combination is raised and lowered using a double-acting connection.

Can be quickly and easily combined with VITASEM ADD or AROSEM ADD implement-mounted drills.

	Working width ft / m	Transport width ft / m	Discs	Disc diameter inch / mm	Disc spacing	Power requirement from
TERRADISC 3001 MULTILINE	9.84 / 3.0	9.84 / 3.0	24	22.83 / 580	4.92 / 125 mm	70 kW / 95 HP
TERRADISC 4001 MULTILINE	13.12 / 4.0	13.12 / 4.0	32	22.83 / 580	4.92 / 125 mm	100 kW / 135 HP

In a single pass



The TEGOSEM cover crop sowing unit combines soil cultivation and sowing a cover crop in a single pass to save time and costs. The TEGOSEM can be combined with PÖTTINGER TERRADISC disc harrows as well as with SYNKRO stubble cultivators. This seed drill can be used together with three-point mounted implements and trailed machines.



Standard equipment and controls

- Metering shaft control & monitoring, output rate electronically adjustable.
- Pre-metering function and headland management.
- Calibration test - calibration at the press of a button.
- Emptying function to drain seed tank.
- Seed level sensor
- DGPS sensor for speed sensor.
- Sensors on top link or chassis for start/stop metering.
- Safe access using platform.
- Small and large seed metering wheel.

TEGOSEM LION

- Tillage and sowing in a single pass
- Fast and cost-effective sowing of cover crops
- Seed distributed either before or after the rear roller
- The outlets are located close to the rear roller to guarantee uniform emergence.
- Loading platform with handrail for convenient and safe filling
- Can be retrofitted to all existing rear rollers.

Cover crop sowing unit



Precision sowing

The seed material is distributed evenly with the TEGOSEM. The metering system is driven electrically. Two different metering cell wheels are provided as standard to ensure precision distribution for small or large seeds even at low seed rates. Eight outlets handle seed distribution.

Reliable seed distribution

The seed material is distributed pneumatically using distribution plates. This guarantees pinpoint precision regardless of the wind conditions. The distributor plates are adjusted by changing the shaft angle. The fan is driven electrically up to a working width of 13.12 ft / 4.0 metres and hydraulically when wider than 16.4 ft / 5.0 metres.

Can be combined with the TEGOSEM:

	For machine type ft / m	Tractor mounting	Fan drive system	Tank location	Tank capacity (litres) gal / l	Weight lbs / kg
TEGOSEM 200	LION 9.84/11.48/13.12 / 3.0/3.5/4.0 FOX / FOX D 9.84/13.12 / 3.0/4.0	Rigid 3-point	Electric fan drive	Rear rollers	53 / 200	319 / 145
TEGOSEM 200	SYNKRO 2520 SYNKRO 3020/3030 SYNKRO 3530	Rigid 3-point	Electric fan drive	Rear rollers	53 / 200	275 / 125
TEGOSEM 500	SYNKRO T 4030 SYNKRO T 5030 SYNKRO T 6030	Folding trailed	Hydraulic fan drive	Drawbar	132 / 500	529 / 240
TEGOSEM 200	TERRADISC 3001 TERRADISC 3501 TERRADISC 4001	Rigid 3-point	Electric fan motor	Rear rollers	53 / 200	275 / 125
TEGOSEM 200	TERRADISC 4001	Folding 3-point	Electric fan motor	Central holder TD	53 / 200	275 / 125
TEGOSEM 200	TERRADISC 5001 TERRADISC 6001	Folding 3-point	Hydraulic fan drive	Central holder TD	53 / 200	297 / 135
TEGOSEM 500	TERRADISC 4001 TERRADISC 5001 TERRADISC 6001	Folding trailed	Hydraulic fan drive	Drawbar	132 / 500	529 / 240

Best working results for seedbed preparation



Intensive crumbling for the best quality tilth and excellent mixing of the soil are the highlights of PÖTTINGER power harrows. Combined with a PÖTTINGER seed drill, this machine becomes a high output and cost-effective combination delivering perfect drilling results.



The rotor gearbox unit – the heart of the machine

- Thick-walled gear trough made of fine-grained steel – extremely resistant to twisting.
- Large gears mounted directly above the bearings.
- Extended inside teething for secure seat on rotor shaft.
- Bearing housing welded to the central brace and bottom of trough. Exact spacing between each rotor.
- Direct transmission of power from the gearbox to the bevel gears.
- Tapered roller bearings with robust, single-piece bearing housing.
- The lower bearings are located as close as possible to the tine carrier.
- The upper and lower bearings are spaced as far apart as possible to minimise stress.

Power harrows



Integrated tine holders

- 0.70 inchw / 18 mm thick, tempered tines attached centrally by just two bolts – makes servicing easy.
- Quick-change tines (optional).
- Bolts and lynch pin are protected from soil ingress and from working loose.
- Perfect interaction of tines and levelling board for the best quality tilth.
- No wrapping of harvest residues.
- The tine carriers are integrated into the casing - stones cannot become trapped between the rotors.
- Slanting front section - earth can flow past unrestricted without bulldozing.



Guided levelling board for reliability and convenience

The height of the levelling board always adapts automatically to the working depth.

- The levelling board is always set perfectly because it is linked directly to the rear roller.
- No adjustment required.
- Set up once at the start of the season.

DURASTAR power harrow tines

PÖTTINGER power harrow tines deliver consistent and low-wear soil preparation which are ideal for mulch drilling.

- Up to 60 % longer service life thanks to special coating.
- Universal tines.
- Excellent geometry retention.

Ideal germination conditions





LION power harrows

Easy mounting on different tractors with different diameter tyres.

- Extend lower linkage mountings without the need for tools.
- Always the ideal setting for the PTO shaft overlap.
- Lower linkage arm provides freedom of movement between tractor and power harrow.

	Working width ft / m	Rotors	Tines inch / mm	Power requirement up to
Power harrows up to 140 hp				
LION 253 CLASSIC	8.20 / 2.50	8	0.71 x 13.39 / 18 x 340	103 kW / 140 HP
LION 303.12 CLASSIC	9.84 / 3.00	12	0.59 x 12.99 / 15 x 330	103 kW / 140 HP
Medium-weight power harrows				
LION 353.14	11.84 / 3.50	14	0.59 x 12.99 / 15 x 330	147 kW / 200 hp
LION 403	13.12 / 4.00	14	0.71 x 13.39 / 18 x 340	147 kW / 200 hp
Heavy-weight power harrows				
LION 3002	9.84 / 3.00	10	0.71 x 13.39 / 18 x 340	184 kW / 250 HP
LION 4002	13.12 / 4.00	14	0.71 x 13.39 / 18 x 340	184 kW / 250 HP
Folding power harrows				
LION 5000	16.40 / 5.00	16	0.71 x 13.39 / 18 x 340	199 kW / 270 HP
LION 6000	19.68 / 6.00	20	0.71 x 13.39 / 18 x 340	199 kW / 270 HP



Testimonial: Tomasz Grzeczka, Poland

"I cover around 46,95 acres / 100 ha every year with the VITASEM 302 ADD and LION 302 combination. This combination has been in operation without any problems for around 3 years in my fields. I use it after ploughing as well as for mulch drilling. I really appreciate that the machine is so flexible and can be adjusted for all working conditions. Setting the machine is easy. The quality of the machinery is very high."

Rear rollers



PÖTTINGER offers a wide range of rear rollers for perfect results with the desired tilth in any type of soil. The whole range of rollers features precision manufacturing and robust design engineering.

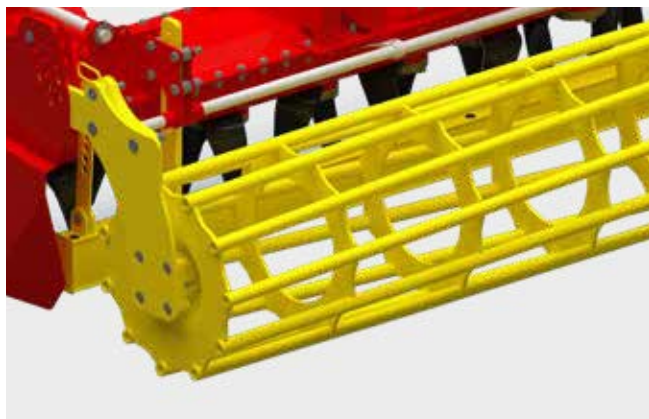

Cage roller

The ideal roller for dealing with dry, non-sticky soils. The roller is fitted with strong bars for optimal consolidation.
Diameter: 16.5 inch / 420 mm, eight bars.
Diameter: 21.3 inch / 540 mm, eleven bars.



Toothed packer roller

This all-rounder is suitable for all types of soil. The roller leaves behind a perfectly consolidated seedbed with loose, fine soil at seed level. The scrapers are located just above surface level. That is why no earth clods can be lifted away, even in wet conditions, and a perfect capillary structure remains intact for optimum germination. The teeth are hardened right through. Coated scrapers also available.
Diameter: 16.5, 19.7 and 21.7 inch / 420, 500 and 550 mm.

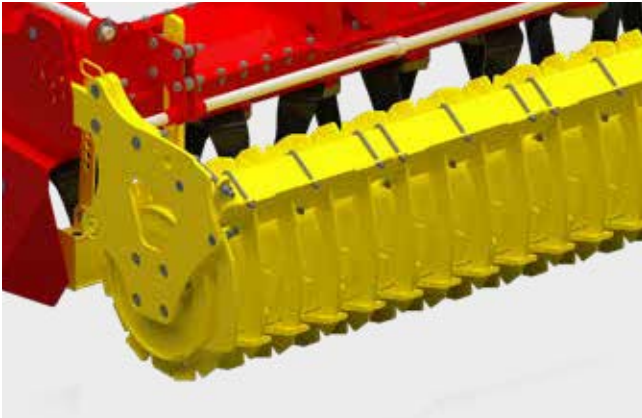

Crumbling packer roller

The teeth are offset at an angle to the left and right. This roller is especially suitable for heavy, clay soils. The result is a deep consolidation effect with loose tilth just under the surface. Coated scrapers (standard) prevent soil sticking to the roller.

Diameter: 20.66 inch / 525 mm.



Pack ring roller

The packer rings are closed on either side and have a diameter of 21.7 inch / 550 mm with eight rings per metre of working width. The roller produces a corrugated consolidation effect to promote drainage and allow the soil to breathe. Ideal for stony, damp conditions and heavy organic residues. Harvest residues remain on the surface of the soil and protect the soil against drying. Coated scrapers (standard) prevent soil sticking to the roller.

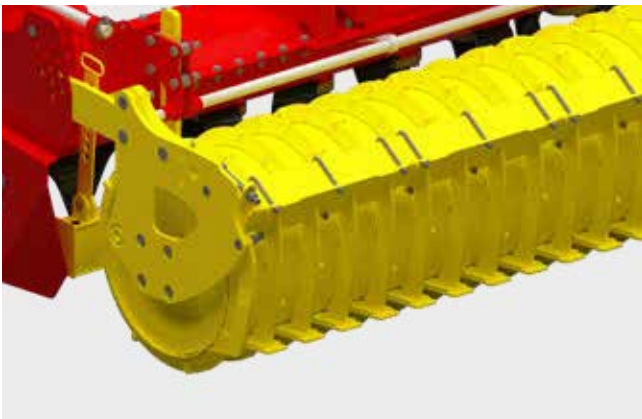

Prism packer roller

Prism rings spaced at 4.92 or 5.90 inch / 12.5 or 15 cm. This roller handles all operating conditions, including stony ground and larger quantities of harvest residues. Re-consolidating in strips, it promotes drainage and breathability of the soil in the area between the rings, which has been subject to less precompaction. Coated scrapers (standard) prevent soil sticking to the roller. Diameter: 19.68, 23.62 / 500 mm, 600 mm.



Rubber packer roller

This roller is ideal for widely varied ground conditions. Especially for use with trailed implements where the load-bearing capacity of other rollers is near the limit. A diameter of 230.31 inch / 585 mm and the special profiling allows the soil to be consolidated in ridges. Coated scrapers (standard) prevent soil sticking to the roller.

Uniform seed placement



PÖTTINGER mechanical seed drills meet the highest demands in terms of functionality, reliability and performance. A unique metering system, uniform seed placement and convenient operation are trademarks that make your work easier.

3 in 1 multi-sow system

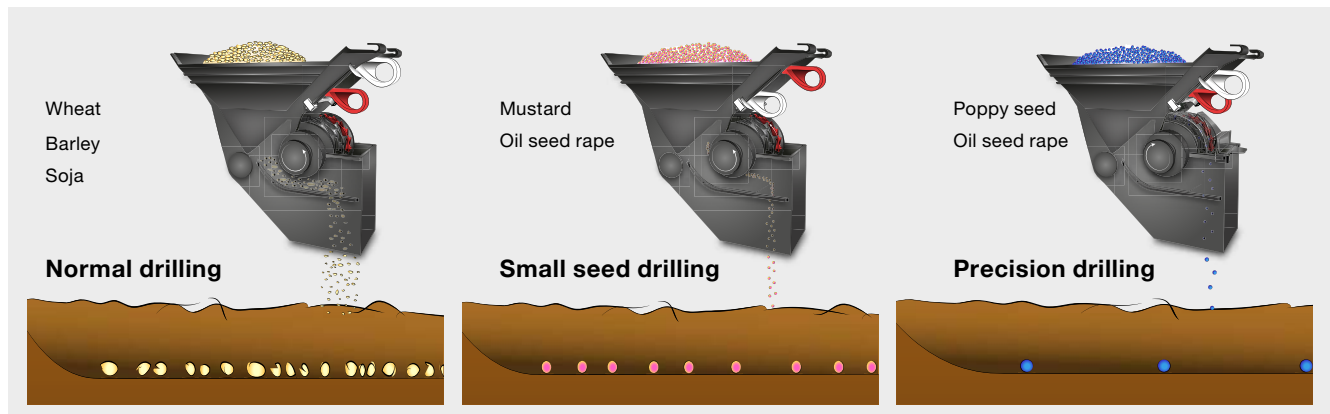

Maximum flexibility with multi-function metering wheel

- Multi-drilling system for seed rates between 0.5 (poppy seed) and 992 lbs /2,47 / 450 kg/ha.
- Three-row multi-functional metering wheel with staggered peg rows.
- Single row small seed metering wheel separated by a slide.
- Partition for quick conversion from normal to small seed drilling – no need to reduce speed.
- Simply change the row spacing by moving the slide.

Unique principle: Perfect seed distribution in seed slot

- Reverse metering option: very similar to precision drilling but for small seeds such as oil seed rape.
- The direction of rotation of the metering shaft is changed by simply switching the gears in the side drive unit.
- Small hollows on the rear of the sowing wheel pegs take only one grain and drop it overhead into the seed funnel.

Mechanical seed drills



Down to the last grain for excellent cost effectiveness

- Funnel-shaped outlets above the metering wheels ensure that the hopper is emptied completely.
- Accurate feed of small seed.
- Uniform distribution even on steep ground.



Precise seed slot with exact depth control

- The rotating scrapers are adjustable and clean effectively.
- Large clearance to the side and an inter coulters rail spacing of 11.81 inch / 30 cm makes the machine resistant to large clods of soil and harvest residues.
- Optional with depth control roller for perfectly controlled seed placement depth.



Ingenious single-disc coulters system

- The diagonal-running PÖTTINGER disc coulters can be used for all applications and is suitable for mulch drilling and working in organic residues.
- The disc coulters open the soil and the wear-resistant casting forms the seed slot and clears organic residues away from the seed placement area. This process guarantees even seed germination.



DUAL DISC coulters

- VITASEM ADD implement-mounted seed drills are equipped with DUAL DISC double-disc coulters.
- Each of the disc coulters is guided by a press wheel to ensure uniform seed placement depth – press wheel diameter 13.77 inch / 350 mm.
- The inter coulters rail spacing of 11.81 inch / 300 mm guarantees large clearance and smooth material flow even with large amounts of organic matter.
- The equal-length coulters arms ensure consistent, uniform coulters pressure.
- Central coulters pressure adjustment.
- Convenient depth settings.

Uniform seed placement



Mechanical seed drills



Highest level of convenience

You can use VITASEM linkage-mounted seed drills on their own or in a combination with soil preparation implements. Thanks to their very low hopper, the seed drill is easy to fill.

	Working width ft / m	Seed hopper gal / l	Rows	Row spacing inch / mm
VITASEM 302	9.84 / 3.0	158/264 / 600 l/1000 l	25 / 21	4.72/5.62 / 120 /143 mm
VITASEM 402	13.1 / 4.0	224/369 / 850 l/1400 l	33 / 27	4.72/5.82 /120 / 148 mm



Maximum flexibility

VITASEM A implement-mounted drills are quickly and easily fitted to the soil preparation implement. In the field the weight of the seed drill acts directly on the rear roller.

This means that the power harrow remains free-moving.

	Working width ft / m	Seed hopper gal / l	Rows	Row spacing inch / mm
VITASEM 302 ADD	9.84 / 3.0	158/264 / 600 l/1000 l	24	4.92 / 125 mm
VITASEM 402 ADD	13.1 / 4.0	224/369 / 850 l/1400 l	32 / 26	4.92 / 125 mm

Best seed germination



The unique AEROSEM seed drill concept from PÖTTINGER unites the drilling of cereals and maize. Precision universal metering and perfect coulter systems guarantee exact placement of the seed.



Intelligent distribution system - flexibility that pays dividends



The newly-developed IDS distribution system controls all outlets via the BUS system. This opens up completely new capabilities in seed row and tramline switching. In conjunction with POWER CONTROL or ISOBUS on the tractor and the electric metering drive, there are now no limits to flexible working in the field.



Precision combined seeding - All-in-one for pure flexibility



PCS integrates precision seed drilling technology into a pneumatic seed drill, making you independent from single seed drills. This means greater flexibility and more cost efficient operation.

Pneumatic seed drill



Exact number of seeds in each row

IDS controls automatic seed rate reduction in the metering system during tramlining and half width switching. The excess seed is returned to the riser tube via the funnel system.

- Consistent number of seeds in each row.
- Uniform crop development.
- Up to 6% saving on seed.



One tank for all jobs

The seed hopper is simply divided for precision seed drilling using PCS and application-specific fertilisation. The partition walls are repositioned quickly and easily using wing-nuts without the need for tools. The hopper offers space for 105 gal / 400 litres of seed (2 x 52.83 gal / 2 x 200 l) and 211 gal / 800 litres of fertiliser. A roll-up tarpaulin cover protects the seed material from dust and rain.

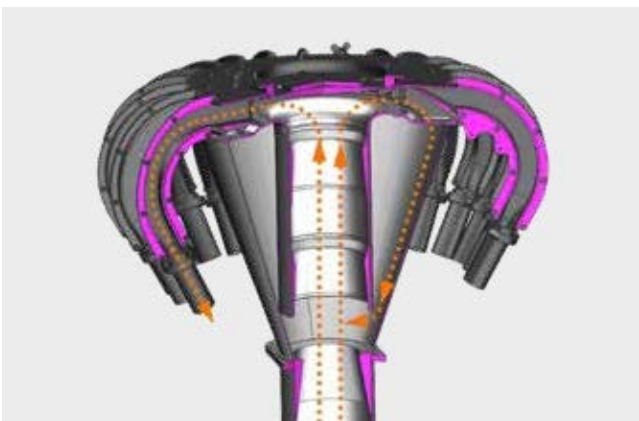

Choose any of the following:

- Row spacing
- Tramline widths
- Track widths
- Special tramline switching
- Dual tramline systems
- Half width switching left and right
- Section Control – partial width switching



Exact seed separation

Several precision metering elements are located beneath the additional hopper funnel. This hydraulically-driven system ensures exact mechanical separation of the seed. The seeds are then transported to the specially-developed injector. The air stream conveys the seed to the coulters.

- Easy adjustment of seeds per m²
- Precise monitoring of seed distribution in the seed slot.

Precision maize drilling



Perfectly placed for uniform emergence

The DUAL DISC coulters with its integrated seed slot former ensures a perfect seed slot. A firming roller presses the seed into the slot. A press wheel controls consolidation and working depth. The seed placement depth can be adjusted centrally.

- No vertical drop.
- Exact seed placement.
- Seed does not roll along slot.
- Optimum covering of seed.
- Uniform seed germination.



For more cost effectiveness

- Reduces the risk of erosion.
- Better shade on the ground - fast row integration.
- Earnings increase in silage maize up to 5.5 % possible.
- Earnings increase in corn maize up to 5.5 % possible.

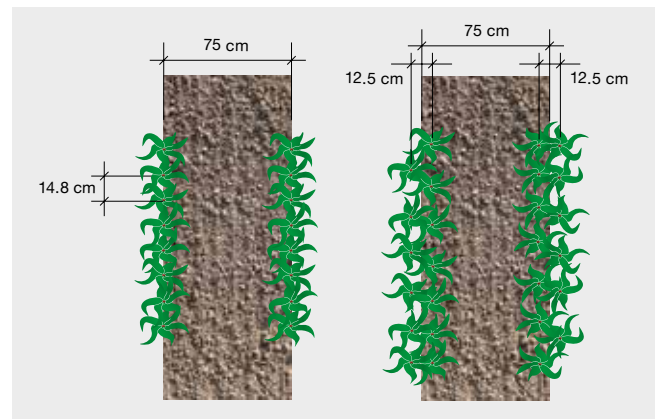

AEROSEM PCS – DUPLEX SEED for perfect plant location conditions

Drilling maize in double rows

- With 4.92 inch / 12.5 cm and double the gap in the row; row spacing 29.52 inch / 75 cm.
- Increases output during sowing thanks to higher driving speed.
- Increase in yield with silage maize and corn maize of up to 5.5 % possible.

Example:
90,000 grains / 2.47/hectare

Pneumatic seed drill



PRECISION COMBI SEEDING - individual seed drilling technology

A seed drill for 5 applications

- Cereals
- maize
- Maize with fertiliser
- Maize with companion crop
- Fertiliser in maize row

How you benefit:

- Expansion in the range of applications - high flexibility.
- Reduction in investment costs by combining a pneumatic seed drill with a precision seed drill.
- Multiple uses for the machine combination.
- No separate precision seed drill required.
- Independence from contractor.
- Make the most of ideal weather and drilling conditions.
- Reduction in fixed operating costs per hectare.

Companion crop for soil conservation and more efficiency

Companion crop is metered precisely in combination with the AEROSEM PCS to be placed exactly between the maize rows.

- Precision drilling and companion crop in one pass.
- Reduces the risk of erosion.
- Better shade on the ground - fast row integration.



AEROSEM pneumatic implement mounted seed drills

For planting cereals, Suffolk coulters, single-disc coulters and DUAL DISC coulters are available. PCS integrates precision seed drilling technology into a pneumatic seed drill, making you independent from single seed drills. This means greater flexibility and more cost efficient operation.

	Working width ft / m	Row spacing inch / mn	Coulter pressure / coulter	Power requirement
AEROSEM 3002 ADD	9.84 / 3.0	4.92 / 125 mm	up to 50 kg (110 lbs)	103 kW / 140 HP
AEROSEM 4002 ADD	13.1 / 4.0	4.92 / 125 mm	up to 50 kg (110 lbs)	140 kW / 190 HP

Efficient drilling



The PÖTTINGER TERRASEM mulch drilling concept combines soil preparation, consolidation and drilling in a single machine. The effective compact disc harrow, unique tyre packer and perfectly designed coulter rail deliver optimum results.

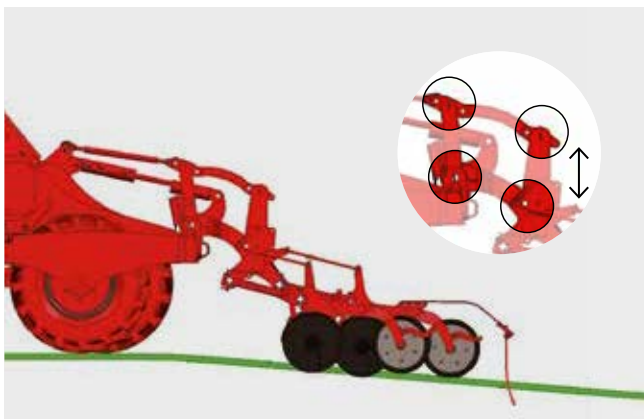

Ultimate ground tracking

- The set pressure on the seed coulter as the rear roller follows the contours of the terrain ensures exact ground tracking.
- The coulter rails are able to track the terrain independently of the packer.
- Coulter rails with coulter arms of the same length – coulter offset is achieved by mounting either on the front or rear rail – ensure 100% consistent coulter pressure.



Three-section design for precise contour guidance

The three-section design of the TERRASEM C drills offers the perfect ground tracking across the whole working width. These frame sections are hydraulically preloaded using nitrogen accumulators to provide equal pressure distribution in any working position over the whole working width. The disc harrow frame sections, packer and coulter rails allow a freedom of movement of up to 5 degrees up and down to adapt to ground contours.

- This guarantees thorough tillage over the whole surface area.
- The placement depth can be adjusted centrally on each three-point unit.



Double-disc coulters

- To achieve consistent placement depth, all coulters are guided by rubber-mounted parallelogram arms that are depth-adjusted by press wheels.
- The depth is adjusted centrally with coulters pressure applied hydraulically between 88 and 265 lbs / 40 and 120 kg.
- The maintenance-free rubber mounting elements provide optimum freedom of movement for each coulters unit.



Safety during road transport

- On the road the machine is transported on four wheels and improve the stability and braking efficiency of the two outer pairs of wheels.
- The middle wheels are raised during transport to provide more stability on uneven field tracks.



IDS – Intelligent Distribution System

The unique IDS controls all outlets via the BUS system. This opens up completely new capabilities in seed row and tramline switching.

Choose any of the following:

- Tramline widths
- Track widths
- Special tramline switching
- Dual tramline systems
- Half width switching left and right



Conserves soil at headlands

- The chassis is fitted with wide tyres to consolidate the soil, each tyre covering four seed rows.
- The wide tyres ensure perfect consolidation ahead of seed placement.
- At the headland the weight of the machine is supported by all the wheels to conserve the soil.
- Each packer wheel is mounted independently to ensure that there is no smearing of the soil, especially at headlands.

WAVE DISC for low disturbance



The maintenance-free WAVE DISCs have a diameter of 20 inch / 510 mm and are available with row spacings of 4.92 and 6.57 inch / 12.5 cm or 16.7 cm. The working depth is infinitely-variable and is controlled by a hydraulic system like the TERRASEM mulch drill. The PÖTTINGER WAVE DISC system is ideal for difficult soil conditions that require reduced tillage and is available for all TERRASEM seed drills.



Working cost-effectively

- Low draft thanks to reduced tillage intensity.
- Less traction required – less soil moved.
- Reduction in erosion – conserves soil structure.
- Earlier sowing time in spring.
- Water saving system.



Suppresses erosion

Low disturbance tillage leaves behind a lower proportion of loosened soil and a smaller cultivated area.

- Less risk of ponding during heavy rain.
- Reduced blowing of light and fine soils in strong winds.

Mulch seed drills



Maximum utilisation thanks to full flexibility – low disturbance

- Water saving strip tillage for dry regions.
- Reduced soil movement for wet regions.

Working convenience for reliable work

- Infinitely-variable working depth adjustment.
- No maintenance required on replaceable WAVE DISCs.
- Disc element with NONSTOP overload protection.



Arable hygiene – the new challenge

- The minimised soil movement creates poor germination conditions, especially for light-dependent germinating weeds such as black grass and brome grass.
- The WAVE DISC low disturbance effect is particularly effective in minimising germination of weed seeds.

Reduced soil movement

Dry region:

- Water saving strips, only the region either side of the seed slot is moved.
- Retards evaporation because none of the remaining surface is moved.

Damp areas:

- Reduced soil movement and less movement of moist soil.
- No deep tools at seed slot level so no smearing.

Efficient drilling



Frontboard

- The frontboard ensures perfect levelling when used in ploughed fields.
- It provides good clearance even with larger levels of harvest residues.
- Hydraulically infinitely adjustable at a maximum working depth of 1.57 inch / 40 mm.
- The levelling board in front of the tyre packer also promotes a fine tilth structure.



Track eradicators

- Breaks up hard tractor wheel marks.
- Working depth of the disc harrow can be reduced.
- Manual, straightforward depth setting, automatic lifting at headland.
- Long service life thanks to hardened steel.
- Three versions available; 1,2 or 3 tines per track.

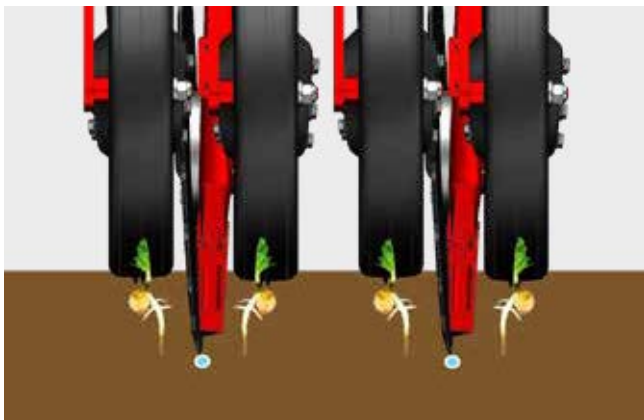

Direct fertilisation

- Fertiliser is placed in rows between each second row of seed; variable placement depth up to 3.93 inch / 10 cm.
- High coulter pressure and reliable penetration of the single-disc coulter.
- Hydraulic adjustment of fertiliser placement depth.
- NONSTOP stone protection on coulters.
- All machine controls and monitoring functions integrated into a single terminal.



FERTILIZER PRO fertiliser coulter for successful drilling

- Flat discs with sealed bearings.
- 16.53 inch / 420 mm diameter.
- 9.84 inch / 25 cm row spacing.
- Coulter pressure up to 396 lbs / 180 kg.
- Plenty of clearance to the side.
- Unrestricted soil flow.

Mulch seed drills



Standard TERRASEM models

The rigid mulch seed drills made by PÖTTINGER have a double row disc harrow or WAVE DISC for soil preparation.

On folding mulch seed drills made by PÖTTINGER, the three-part configuration ensures perfect ground tracking. The outer elements have plenty of freedom of movement.

	Working width ft / m	Seed box / incl. support gal / l	Rows Standard	Row spacing Standard inch / mm	Rows Optional	Row spacing Optional inch / mm
TERRASEM R – rigid version						
TERRASEM R3	9.84 / 3.00	1043 / 3950	24	4.92 / 125	18	6.57 / 167
TERRASEM R4	13.12 / 4.00	1043 / 3950	32	4.92 / 125	24	6.57 / 167
TERRASEM C – folding version						
TERRASEM C4	13.12 / 4.00	1043 / 3950	32	4.92 / 125	24	6.57 / 167
TERRASEM C6	19.69 / 6.00	1043 / 3950	48	4.92 / 125	36	6.57 / 167
TERRASEM C8	26.25 / 8.00	1347 / 5100	64	4.92 / 125	48	6.57 / 167
TERRASEM C9	29.53 / 9.00	1347 / 5100	72	4.92 / 125	54	6.57 / 167



TERRASEM FERTILIZER PRO with direct fertilisation

Using direct fertilisation enables you to apply fertiliser at the same time as drilling the seed. This enables you to achieve optimum growth conditions during the early phase of seed growth and increase the generative performance of the seed. With the TERRASEM FERTILIZER PRO models from PÖTTINGER, the placement depth of fertiliser and seed can be set individually.

		Working width ft / m	Seed box / incl. support	Rows, standard Seed / fertilizer	Row spacing Standard	Rows, optional Seed / fertilizer	Row spacing Optional inch / mm
TERRASEM R3 FERTILIZER PRO	NEW	9.84 / 3.00	1347 / 5100	24 / 36	4.92 / 125	18 / 27	6.57 / 167
TERRASEM R4 FERTILIZER PRO	NEW	13.12 / 4.00	1347 / 5100	32 / 48	4.92 / 125	24 / 33	6.57 / 167
TERRASEM C4 FERTILIZER PRO	NEW	13.12 / 4.00	1347 / 5100	32 / 48	4.92 / 125	24 / 33	6.57 / 167
TERRASEM C6 FERTILIZER PRO	NEW	19.69 / 6.00	1347 / 5100	48 / 70	4.92 / 125	36 / 54	6.57 / 167
TERRASEM C8 FERTILIZER PRO	NEW	26.25 / 8.00	1347 / 5100	64 / 96	4.92 / 125	48 / 72	6.57 / 167
TERRASEM C9 FERTILIZER PRO	NEW	29.53 / 9.00	1347 / 5100	72 / 108	4.92 / 125	54 / 81	6.57 / 167

Best forage



Best forage

Better forage keeps animals healthier. Healthier animals produce more milk. And more milk means more success for your business. As a farmer you will already know that at every stage it is worth improving the quality of base forage as far as possible. The bottom line is that the highest quality base forage is the cornerstone for healthy livestock and decent profit in your business.

Mowers – with unique ALPHA MOTION ground tracking

- The mower moves virtually on a vertical plane, minimising telescoping of the PTO shaft and greatly reducing dynamic stress.
- Two powerful highly responsive springs in the headstock: Perfectly balanced weight alleviation over the whole working width. The mower can be driven at high speed without the cutter bar rising.
- A huge ground clearance of 13.77 inch / 350 mm is provided at headlands and in the transport position. You can drive over swaths without damaging them and transport the mower on bumpy tracks.

PÖTTINGER grassland machines

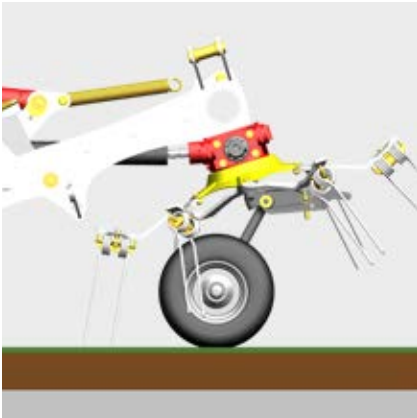

Tedders conserve the sward with LIFTMATIC/ LIFTMATIC PLUS

- Before being raised, the rotors are positioned horizontally using a hydraulic cylinder and then lifted. The tines do not touch the ground during lifting or during lowering.
- In addition, the high headland position of 35.43 inch / 90 cm clearance prevents the tines from penetrating or scraping the ground. The forage remains clean and the sward is protected.



Rakes - keeping forage clean thanks to MULTITAST

The DLG Focus Test "Ground tracking and forage contamination in grass silage" in November 2013 confirms: The PÖTTINGER MULTITAST wheel delivers ideal ground tracking and clean forage.

The rotor with the MULTITAST wheel causes around 25 % less raw ash/contamination in the forage.

- 2.3 % more raw ash means 456 lbs / 207 kg dirt/ha for a yield of 90 dt DM/ha.
- Raw ash content without MULTITAST wheel: 12.4 % Raw ash content with MULTITAST wheel: 10.1 %



Loader wagons - clean forage thanks to excellent ground tracking

- Height-adjustable 16 x 6.5-8 trailed jockey wheels ensure perfect ground tracking.
- Two jointed support arms ensure the pick-up has complete freedom of movement, even diagonally.
- A spring also alleviates the pick-up weight so less pressure is exerted on the ground.
- A support roller can also be fitted behind the pick-up if required for even better tracking on soft ground.

First class cut



A precision mowing process is the starting point for high forage quality. Best-possible ground tracking, minimal losses and precision when working without time-consuming operation are what the industry demands. Our mowers ensure first-class cutting quality, smooth operation and strength.



Clean forage, cut for cut.

The slanted leading edge of the cutter bar allows the soil to flow beneath, separating it cleanly from the crop. Cleaning paddles prevent dirt from accumulating on the mower disc. The rounded disc surfaces improve the conveyor effect across the cutter bar. The welded and extremely flat cutter bar enables optimum crop flow. The clamped quick change mower blades rotate very close to the surface of the cutter bar and the counter knife. The optimal overlap of blade paths ensures a clean and uniform mowing pattern.



More service life

The spur gear driveline runs in a straight path with virtually the same sized gears. On the gears there are always three teeth in contact with each other – this ensures optimum power transmission. Moreover, there is less stress on the individual gears in the event of stone impact. The specially ground surface of the gears submerged in gear oil ensures smooth running. This reduces the noise level considerably.

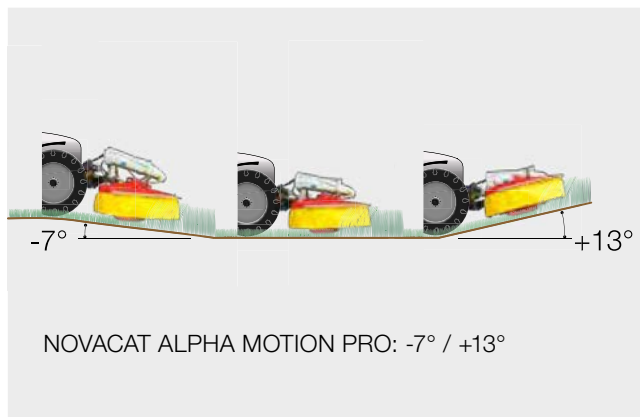

Simply tidy mowing: ALPHA MOTION

- The active supporting frame and link rods guide the cutter bar over every undulation in the ground: The cutter bar rises and floats over each bump and glides down each dip.
- Unique freedom of transverse movement +/- 16° thanks to gimbals on the linkage arms.
- Perfect view of the work area from the tractor seat thanks to sleek design of the headstock.



New: ALPHA MOTION PRO

The new NOVACAT ALPHA MOTION PRO front mower features a new design, delivers the first-class ground tracking you expect from our machinery, and makes your working day a great deal easier: A central greasing point on the headstock makes servicing easier. The front guard can easily be folded up and locked in place to provide the best access to the suspension springs.

The machine is available with or without conditioner.

First class cut



NOVACAT 302 with a vertical transport position

Our NOVACAT rear mowers with centre pivot mounting feature optimum weight alleviation and float over any unevenness in the ground. A practical transport position is achieved by raising the mower through 115°. This keeps the transport height as low as possible. The view to the rear is unrestricted via both exterior mirrors.



NOVACAT 352 / 402 / 442 with a horizontal transport position

The top end of our rear-mounted mower range without conditioners is represented by the NOVACAT 402 and 442 with working widths of 12.72 ft / 3.88 m and 14.1 ft / 4.30 m. A narrow and low transport position is possible by folding the mowers backwards hydraulically. Now you can keep an eye on everything behind you during transport.



Cost-effective and suitable for working on slopes: NOVADISC rear-mounted mowers

The new generation of NOVADISC rear mowers with side pivot mounting are real lightweights and can be operated with tractors starting at 40 HP. They are designed to operate reliably on steep ground and for mowing embankments. Two suspension springs guarantee the cutter bar applies hardly any pressure to the ground. Weight alleviation is adjustable in three stages without the need for tools. For a compact transport position, the mower is folded through 102°.



Proven high output technology: NOVACAT X8 mower combination

NOVACAT X8 mower combinations are high output and economical. These mowers can be used as front/rear-mounted combinations or in a reverse drive push configuration.



NOVACAT A9 / A10 mower combinations

The NOVACAT A9 mower combination is a front/rear combination with a fixed working width of either 29.26 ft / 8.92 m or 30.11 ft / 9.18 m with 2 mounting positions. The NOVACAT A10 mower combination is a front/rear combination with a hydraulic cutting width optimisation system. The NOVACAT A10 is a front/rear combination with a fixed working width of either 28.87 ft / 8.8 m or 32.87 ft / 10.02 m with 2 mounting positions. This enables flexible width adjustment to differing operating conditions.



Maximum output and cost effectiveness: NOVACAT S10 / S12 mower combinations

With the NOVACAT S mower combinations, PÖTTINGER sets new standards in terms of high output and efficiency. The NOVACAT S12 is the largest mounted mower combination available on the market. It gives you a full working width of 36.74 ft / 11.20 m with a power requirement of just 160 HP and the lowest fuel consumption. For the NOVACAT S10, tractors starting at 130 HP are all that is needed.



Proven swath merging system: COLLECTOR

With the COLLECTOR system, the crop can be placed to meet your requirements: as a wide blanket, in a swath, or wide-spread to one side. The cross conveyor belts can be pivoted hydraulically individually and can be easily removed if required. You have great flexibility in setting belt speeds. Uniform swath placement is possible even on steep ground.

First class cut



ED tine-type conditioner RCB roller-type conditioner

PÖTTINGER offers two different types of conditioner for a wide range of mower models:

- ED: V-shaped tines hit the stalks in the crop and guarantee fast drying.
- RCB: The rollers inter-mesh to uniformly crimp especially leafy crops and produce a uniform blanket of forage.

Swath merging without a conditioner: CROSS FLOW

CROSS FLOW is a cost effective swath merging system using an auger integrated into the mower. CROSS FLOW works without a conditioner and is characterised by its light tare weight. The hydraulic rear panel opening system makes things even easier. Available for NOVACAT A10, NOVACAT 352 and now also for the NOVACAT 302.



Trailed mowers - Clean forage wherever you go

The PÖTTINGER trailed disc mowers mow perfectly on all surfaces, even in uneven and undulating ground conditions. You are sure to get three-dimensional ground tracking thanks to the freedom of movement enabled by the cutter bar being suspended in the portal frame. This guarantees you the best forage in any terrain.



NOVACAT front-mounted disc mowers

The NOVACAT ALPHA MOTION delivers perfect weight alleviation and optimum ground tracking.

		Working width ft / m	Mowing discs	Area efficiency acres / ha	Weight SF lbs / kg	Weight with ED lbs / kg	Weight with RCB lbs / kg
NOVACAT 301 ALPHA MOTION PRO	NEW	9.97 / 3.04	7	7.40 / 3.00	1995 / 905	2524 / 1145	2700 / 1215
NOVACAT 351 ALPHA MOTION PRO	NEW	11.35 / 3.46	8	8.40 / 3.40	2171 / 985	2788 / 1265	2899 / 1315

SF = swath former, ED = EXTRA DRY tinc conditioner, RCB = ROLLER CONDITIONER BELT

First class cut



NOVADISC & NOVACAT - rear-mounted disc mowers

Our smooth-running NOVADISC mowers with side pivot mounting stand for high output and a clean cut at the lowest power requirement. With our NOVACAT centre pivot-mounted rear mowers, you experience excellent ground tracking and weight alleviation.

		Working width ft / m	Number of discs	Area efficiency / h acres / ha	Weight SF lbs / kg	Weight with ED lbs / kg	Weight with RCB lbs / kg
Rear disc mowers with side pivot mounting, without conditioner							
NOVADISC 222	NEW	7.21 / 2.20	5	5.4 / 2.20	1399 / 635	–	–
NOVADISC 262	NEW	8.59 / 2.62	6	6.4 / 2.60	1488 / 675	–	–
NOVADISC 302	NEW	9.97 / 3.04	7	7.4 / 3.00	1576 / 715	–	–
NOVADISC 352		11.35 / 3.46	8	8.4 / 3.40	1675 / 760	–	–
Rear disc mowers with centre pivot mounting							
NOVACAT 302		9.97 / 3.04	7	7.40 / 3.00	2050 / 930	2778 / 1260	2932 / 1330
NOVACAT 302 CF	NEW	9.97 / 3.04	7	7.40 / 3.00	3086 / 1400	–	–
NOVACAT 352 V		11.35 / 3.46	8	8.50 / 3.40	2270 / 1030	–	–
NOVACAT 352		11.35 / 3.46	8	8.50 / 3.40	2160 / 980	2954 / 1340	3064 / 1390
NOVACAT 352 CF		12.72 / 3.88	9	9.88 / 4.00	3219 / 1460	–	–
NOVACAT 402		14.11 / 4.30	10	11.10 / 4.50	2292 / 1040	–	–
NOVACAT 442		14.11 / 4.30	10	11.10 / 4.50	2380 / 1080	–	–



NOVACAT – mower combinations

The PÖTTINGER mower combinations are high output and economical. Depending on the model, these mowers can be used as front/rear-mounted combinations or in a reverse drive butterfly configuration. Thanks to the swath merging COLLECTOR and CROSS FLOW, our mower combinations are even more versatile.

	Working width ft / m	Number of discs	Area efficiency / h acres / ha	Weight SF lbs / kg	Weight with ED lbs / kg	Weight with RCB lbs / kg
NOVACAT X8	27.23 / 8.30	2 x 7	24.71 / 10	4761 / 2160	4982 / 2260	6128 / 2780
NOVACAT A9	29.26/30.11 / 8.92/9.18	2 x 8	29.65 / 12	4982 / 2260	6569 / 2980	6746 / 3060
NOVACAT A10	28.87/32.87 / 8.8/10.02	2 x 8	29.65 / 12	5180 / 2350	6790 / 3080	6966 / 3160
NOVACAT A10 CF	28.87/32.87 / 8.8/10.02	2 x 8	29.65 / 12	7297 / 3310	–	–
NOVACAT A10 COLLECTOR	28.87/32.87 / 8.8/10.02	2 x 8	29.65 / 12	–	8333 / 3780	8774 / 3980
NOVACAT S10	29.85/31.23 / 9.10/9.52	2 x 8	27.18 / 11	3968 / 1800	–	–
NOVACAT S12	35.36/36.74 / 10.78/11.20	2 x 10	32.12 / 13	4497 / 2040	–	–



NOVACAT T – Trailed mowers

Trailed NOVACAT T mowers are ideal for cutting heavy crops. We achieve perfect three-dimensional ground tracking thanks to the fully-floating mower unit with optimised spring positions. The NOVACAT T models are available with COLLECTOR swath merging.

	Working width ft / m	Number of discs	Area efficiency / h acres / ha	Weight SF	Weight with ED lbs / kg	Weight with RCB lbs / kg
NOVACAT 307 T	9.97 / 3.04	7	8.90 / 3.60	–	4389 / 1991	4522 / 2051
NOVACAT 3007 T	9,97 / 3.04	7	8,90 / 3.60	–	4698 / 2131	4828 / 2190
NOVACAT 3507 T	11.35 / 3.46	8	10.38 / 4.20	–	4863 / 2206	5040 / 2286
NOVACAT 3507 T COLLECTOR	11.35 / 3.46	8	10.38 / 4.20	–	6228 / 2825	6371 / 2890



Customer report: Daniel Showalter, USA

"We own a custom mowing operation of bio-mass and alfalfa on about 6,000 acres / 2,400 ha that we farm with our several PÖTTINGER machines including a NOVACAT V10/NOVACAT 351 alpha-motion triple mower combination. We mow about 4,000 acres / 1,600 ha with our equipment per year. Since we are doing custom mowing, hundreds of miles from home, we have to have dependable machinery and service. From time to time, we take advantage of the PÖTTINGER service team and we give it 10 out of 10 points for reliability and quality. We are very satisfied with all our PÖTTINGER equipment. The features we like most about our triple mower combination are the fuel efficiency as well as the front mower suspension. For us PÖTTINGER stands for high quality hay equipment and the best service."

The neatest spread pattern



Our proven rotary tedders deliver perfect ground tracking. Tedding crops carefully without dirt ingress is the result. The wide wheels together with the MULTITAST jockey wheel on the headstock greatly improve performance on slopes. High manufacturing quality guarantees a long service life.

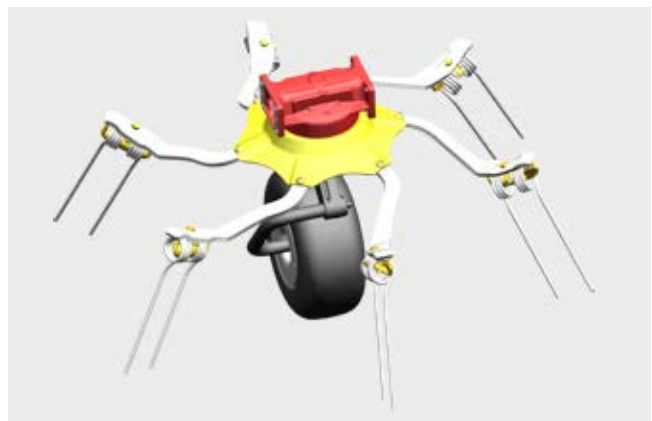

Best forage quality

Clean forage packed with energy is the prerequisite for healthy, high yield livestock. Choose PÖTTINGER and optimise your forage quality. Our HIT tedders are designed to treat your forage carefully. Our machines work extremely tidily.

Four times cleaner with DYNATECH

- Cleanly collected crop is guaranteed thanks to the small diameter of our DYNATECH rotors.
- The optimum ground tracking of the individual rotors keeps your forage clean.
- The ideal spreading angle ensures that the forage is spread cleanly and evenly.
- The sweeping action of the tines ensures that the tines are kept free of forage.



Perfect ground tracking

The proven PÖTTINGER MULTITAST jockey wheel system keeps your forage clean and conserves the sward. The optional jockey wheel on the pivoting headstock tracks the ground immediately in front of the tine path and responds to each undulation. The tines do not touch the ground. In addition, wear to the tines is reduced considerably.



Optimum working results on every job

Tedding while cornering is easy and convenient thanks to the short headstock with horizontal pivot guidance. Stabiliser struts make sure that the machine is always centred, which is especially helpful on steep ground. You HIT also runs smoothly at high operating speeds.



Reliable and durable

Our HIT tedders work with precision and at the same time are very smooth running. This is thanks due to backlash free drive joints. The maintenance free PTO shafts and constant velocity joints ensure that the tines are precisely spaced to pick up and spread the forage perfectly uniformly. Wear remains low. The joints can be rotated in every position, eliminating the possibility of operator error.



Compact and safe during transport

In the transport position, the raised rotors are tilted close to the tractor. This favourable distribution of weight provides enhanced safety while driving. Narrow and low transport dimensions make road transport and storage easier.

The neatest spread pattern



HIT – four rotor tedders

The highest requirements of small to medium-sized farms are met in full by our 4-rotor tedders. Designed for all forage types, these machines provide you with optimum distribution quality and perfect crop take-up.

	Working width DIN ft / m	Transport width ft / m	Rotor	Arms per rotor	Weight lbs / kg
HIT 4.54	17.06 / 5.2	9.35 / 2.85	4	6	1212 / 550
HIT 4.54 T	17.06 / 5.2	9.35 / 2.85	4	6	1411 / 640



HIT – six rotor tedders

The tedder series with six rotors is for farmers who value high specifications and ease of use. These six-rotor machines provide excellent ground tracking, the best crop take-up and a uniform spread pattern.

	Working width DIN ft / m	Transport width ft / m	Rotor	Arms per rotor	Weight lbs / kg
HIT 6.80	24.44 / 7.45	9.84 / 3.0	6	6	
HIT 6.80 T	24.44 / 7.45	9.84 / 3.0	6	6	



HIT – eight rotor tedders

Our eight rotor tedders are designed especially for professionals. You will be impressed by how convenient they are to operate. The DYNATECH rotors guarantee even better working quality with the best forage protection.

	Working width DIN ft / m	Transport width lbs / kg	Rotor	Arms per rotor	Weight lbs / kg
HIT 8.91	28.22 / 8.6	9.84 / 3.0	8	6	2755 / 1250



HIT T – trailed high output tedders

With these trailed HIT T tedders, we at PÖTTINGER combine high output with intelligent technology. Our models feature ingenious lifting geometry. This means you can raise the tedder into the headland position quickly and easily.

	Working width DIN ft / m	Transport width ft / m	Rotor	Arms per rotor	Weight lbs / kg
HIT 8.9 T	28.22 / 8.6	9.51 / 2.9	8	6	3858 / 1750
HIT 10.11 T	34.77 / 10.6	9.51 / 2.9	10	6	4619 / 2095
HIT 12.14 T	41.67 / 12.7	9.51 / 2.9	12	6	5236 / 2375



Testimonial:

Boydston Hay Farm LLC, Henagar Alabama, USA

"We run a beef cattle, cash crop and hay operation totaling 1,100 acres / 450 ha. As our custom hay operation grows and quality forage becomes more important, dry down time can become a bottleneck when tedding over 1,500 acres / 600 ha per year. We needed a larger tedder and came across the HIT 12.14 T. We are really impressed how easy the machine is to use and like the way a machine of this size can flex to the contour of all landscapes. It operates in fields with terraces just as well as in flat fields. Due to its large size we are now able to do the work of three machines with just one tedder, tractor and operator resulting in cutting back labor and fuel cost by 2/3."

TOP forage quality



Our smooth running PÖTTINGER rakes solve the full range of challenges met in the field. They deliver perfect ground tracking and are extremely manoeuvrable. Tidy raking with the lowest possible disintegration losses guarantee that you obtain the best forage quality.

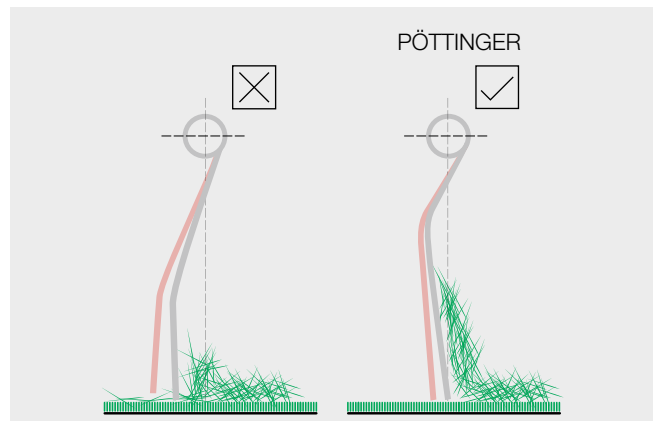

Precision raking without touching the ground

Raking has a decisive influence at the end of the harvest chain on how clean the forage remains. Our tines do not contact the ground and comb the forage carefully out of the sward. This means that much less raw ash enters your base forage.

Careful forage handling

PÖTTINGER tines have decades of proven performance behind them. They point towards the ground directly under the tine arm and are angled slightly forward, without any need for a steep offset angle. The resistance of the forage presses them back slightly, but without lifting them – so they pick up all of the forage. In connection with the MULTITAST jockey wheel system you have the perfect starting point for clean and tidy swaths.

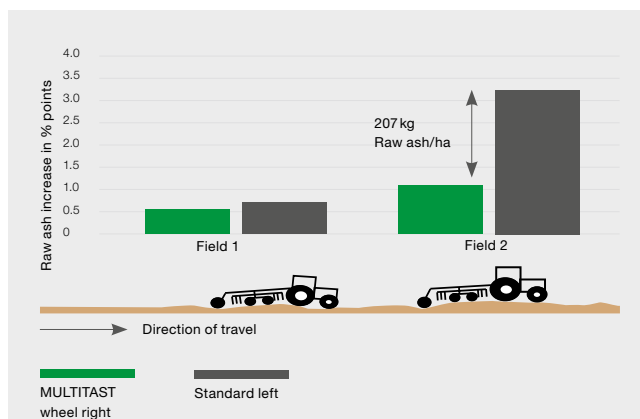
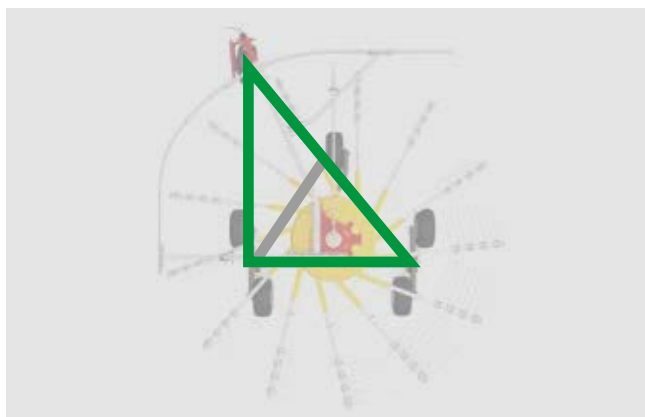

DLG confirms forage conservation with PÖTTINGER MULTITAST jockey wheel

- The MULTITAST wheel makes the support triangle much larger. This makes the rotors run more smoothly and suppresses vibrations
- 25 % less raw ash/dirt enters your forage.

The DLG Focus Test "Ground tracking and forage contamination in grass silage" confirms: The PÖTTINGER MULTITAST wheel delivers ideal ground tracking and clean forage.

The test was performed using the TOP 762 C twin rotor centre-swath rake. The right-hand rotor was fitted with a MULTITAST wheel, while the left-hand rotor was equipped with a standard chassis without MULTITAST wheel.

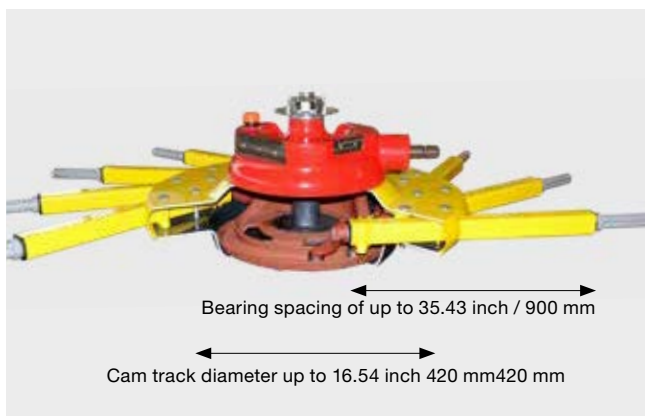

TOPTECH PLUS – reliable and durable

Our rotor units are built so that the stress on the bearings is as low as possible. This results in wear being kept to a minimum. The large diameter cam track with its smooth ramps makes sure that the tines exit the swath ergonomically. The swath shape can be adapted to your special operating conditions using the adjustable cam track.

Service friendly and convenient

The tine arms are removable to reduce width during transport and height for storage. These are easy to plug in; it is not possible to slot them in incorrectly. The whole tine arm can be exchanged quickly and easily in the event of any damage. No grease is needed for the cam track. Additionally, the tine arm bearings are also maintenance-free.

TOP forage quality



TOP – single rotor rake

Our manoeuvrable single rotor machines are the ideal choice for smaller fields. For big raking power with smaller tractors, the TOP 421 A TOPTECH PLUS and TOP 461 A TOPTECH PLUS are also available as trailed machines.

	Working width ft / m	Transport width ft / m	Tine arms	Tine pairs per arm	Weight lbs / kg
TOP 342	11.15 / 3.4	6.4 / 1.95	10	4	1045 / 474
TOP 382	12.47 / 3.8	6.4 / 1.95	11	4	1091 / 495
TOP 422	13.78 / 4.2	7.51 / 2,29	12	4	1609 / 730
TOP 462	15.09 / 4.6	7.51 / 2,29	12	4	1687 / 765
TOP 421 A TOPTECH PLUS	13.78 / 4.2	7.74 / 2.36	12	4	1753 / 795
TOP 461 A TOPTECH PLUS	15.09 / 4.6	7.74 / 2.36	12	4	1830 / 830



TOP – twin rotor rake with side swath placement

Our side rakes can easily be adapted to different crop conditions and harvesting technology. We enable the perfect ground tracking delivered by PÖTTINGER rakes thanks to the optimised setup and independent movement of the rotors.

	Working width ft / m	Transport width ft / m	Tine arms	Tine pairs per arm	Weight lbs / kg	Weight
TOP 722	22.31 – 24.93 / 6.8 – 7.6	9.51 / 2.9	2 x 13	4	right	5489 / 2490
TOP 812	24.93 / 7.6	9.51 / 2.9	2 x 13	4	right	6195 / 2810
TOP 611 A TOPTECH PLUS	11.15 – 20.34 / 3.4 – 6.2	6.89 / 2.1	2 x 12	4	left	3726 / 1690
TOP 691 A TOPTECH PLUS	13.78 – 23.35 / 4.2 – 7.1	7.87 / 2.4	2 x 12	4	left	3814 / 1730



TOP C – twin rotor rake with centre swath placement

The advantage of our centre-swath rakes is their uniform and airy swath placement. They are especially manoeuvrable and easy to operate. Our centre-swath rakes guarantee a perfectly matched swath for the next machine in the harvest chain.

	Working width ft / m	Transport width ft / m	Tine arms	Tine pairs per arm	Weight lbs / kg
TOP 702 C	20.50 – 22.63 / 6.25 – 6.9	9.51 / 2.9	2 x 11	4	3704 / 1680
TOP 762 C	22.15 – 24.61 / 6.75 – 7.5	9.51 / 2.9	2 x 13	4	4277 / 1940
TOP 842 C	25.26 – 27.56 / 7.7 – 8.4	9.51 / 2.9	2 x 13	4	5688 / 2580
TOP 962 C	29.20 – 31.50 / 8.9 – 9.6	9.68 / 2.95	2 x 15	4	6900 / 3130



TOP C – four rotor rake

Short harvesting windows necessitate high performance harvesting technology. With the professional TOP 1252 C series we offer you a powerful centre-swath rake with the highest possible output.

	Working width ft / m	Transport width ft / m	Rotors	Tine arms	Tine pairs per arm	Weight lbs / kg
TOP 1252 C	26.25 – 41.01 / 8.0 – 12.5	9.84 / 3.0	4	4 x 13	4	13922 / 6315



Testimonial: Christian Litzllachner, Amstetten, Austria

"I have a farm with dairy cattle and also breed young stock. We are family-owned with 98.84 acres / 40 ha grassland and 123.55 acres / 50 ha arable. I am very impressed with the build of PÖTTINGER machinery, which is why I own several of their implements. What I really appreciate about my TOP 722 rake is its reliability. PÖTTINGER offers excellent customer care as well as a spare parts service that has worked perfectly so far."





The world leader in loader wagons



It's harvest time – the highest quality of forage must be brought in. High forage quality saves having to use expensive concentrates and delivers a higher yield. It is good to know that you are saving in several places at once. That is because the loader wagon is the undisputed forage harvesting process with the lowest costs.



More efficient and and more powerful

The PÖTTINGER pick-up guarantees maximum feed rate. The transfer zone from the pick-up tines to the rotor has been optimised and adapted to high throughHPut The Pöttinger floating pick-up with eight rows of tines delivers impressive performance – even at high driving speeds and in difficult harvest conditions – for reliable high speed intake.

POWERMATIC PLUS is the heart of JUMBO series loader wagons. Rugged, powerful and designed for virtually unlimited tractor power, this rotor delivers high throughHPut during chopping and compression. POWERMATIC PLUS represents smooth, efficient collection of the crop and perfect transfer from the pick-up.

Rotary loader wagons



The highest forage quality

High yield dairy cattle need high quality base forage with the optimum structure. This is readily consumed by the animals in sufficient quantities. That is the best way to prepare the rumen to process the forage as productively as possible.

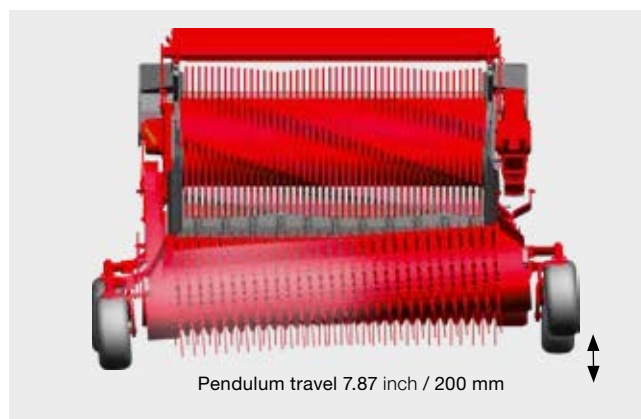

The PÖTTINGER pick-up delivers impressive performance – even at high driving speeds and in difficult harvest conditions – for reliable high speed intake. This newly-developed additional tracking roller is located behind the middle of the pick-up on PÖTTINGER loader wagons. Being located in the centre prevents it from sinking into tractor wheel marks and as a result guarantees perfect ground tracking and clean forage.



The highest silage quality

To achieve good fermentation in the silo, the forage must be chopped precisely and cleanly. Thanks to the short-chop knife bank, the flow of forage is cut right through precisely and uniformly. This ensures ideally structured ruminant stimulating forage. An optimum distance between the knives and tines ensures smooth operation and protects the knives from foreign objects.

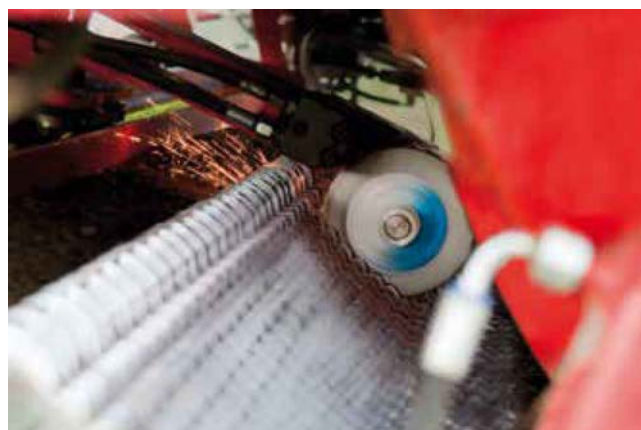

A precise and consistent chop is the basis for the best silage quality. AUTOCUT delivers consistent chopping quality throughout a whole working day. The AUTOCUT knife sharpening system enables convenient knife sharpening directly on the loader wagon.

The world leader in loader wagons



FARO / FARO COMBILINE – loader wagons with rotors

With the FARO series, we meet your demand for high performance rotor technology for medium sized tractors. The rotor with dual tines is especially suitable for handling hay.

	Volume, DIN cu ft / m³	Knives	Cutting length inch / mm	Power requirements
FARO 4510 L / D	1059 / 1024 / 30 / 29	31	1.77 / 45	66 – 110 kW / 90 – 150 HP
FARO 5010 L / D	1165 / 1130 / 33 / 32	31	1.77 / 45	66 – 110 kW / 90 – 150 HP



EUROPROFI – multi-purpose loader wagons with rotors

Our EUROPROFI series has stood for easy operation, performance and convenience in harvesting for more than 20 years. Even higher performance, able to handle a variety of tasks and delivering a chopped length of 1.54 inch / 39 mm – our customers really like this wagon concept.

	Volume, DIN cu ft / m³	Knives	Cutting length inch / mm	Power requirements
EUROPROFI 5010 L / D COMBILINE	1024 / 988 / 29 / 28	35	1.54 / 39	96 – 162 kW / 130 – 220 HP
EUROPROFI 5510 L / D COMBILINE	1130 / 1095 / 32 / 31	35	1.54 / 39	96 – 162 kW / 130 – 220 HP

Rotary loader wagons



TORRO – multi-purpose wagon with loading rotor

The high-performance TORRO fulfils all your needs for cost-effective silage harvesting. This range gives you high output and reliable performance for high capacity harvesting operations.

		Volumen DIN cu ft / m ³	Knives	Cutting length inch / mm	Power requirements
TORRO 6010 L / D COMBILINE	NEW	1112/1076 / 31,5/30,5	45	1.34 / 34	118 – 221 kW / 160 – 300 HP
TORRO 6510 L / D COMBILINE		1235/1200 / 35/34	45	1.34 / 34	118 – 221 kW / 160 – 300 HP



JUMBO COMBILINE – multipurpose loader wagons with rotors

With the combination loader wagon JUMBO combiline, we can deliver maximum flexibility and increased machine utilisation. As a highly productive loader wagon and harvest transport wagon, the JUMBO COMBILINE provides you with a true master of all trades.

		Volume, DIN cu ft / m ³	Knives	Cutting length inch / mm	Power requirements
JUMBO 7220 L / D COMBILINE	NEW	1465 / 1416 / 41.5 / 40.1	45	1.34 / 34	118 – 331 kW / 160 – 450 HP

For all operating conditions



Agriculture needs reliability. Regardless of whether the sun is shining or it is raining, regardless of whether baling straw, hay or silage – the reliability of our round balers in all operating conditions is a key feature of the PÖTTINGER IMPRESS.



Versatility for all crop types

One machine for all operating conditions.

- Controlled pick-up for perfect ground tracking and cleanly collected crop.
- LIFTUP rotor technology for a natural flow of crop. Guaranteed to get the bale started with four starter rollers.

Reliable bale start with 32 knives engaged in virtually all operating conditions.



The perfect flow – unique crop flow path

Literally redefining the crop flow into the baler has brought about many positive advantages:
The new LIFTUP technology enables a natural flow of crop, so that the forage enters the bale chamber tangentially at an ideal angle.
The long transfer throat ensures crop is wrapped tidily. This helps the bale retain its shape even when handled multiple time.



The highest forage quality

IMPRESS PRO models achieve a unique theoretical chopped length of 1.41 inch / 36 mm across the full width of the rotor.

The new, pull-out FLEXCUT 32 short chop system features 32 TWIN BLADE reversible knives.

PÖTTINGER, the world leader in loader wagons, has thus managed to integrate loader wagon chop quality into a round baler for the first time. Short chop not just for silage, but also for hay and straw. That is unique.

The knives are produced from hardened tool steel and their pressed serrated edge ensures a precise chop. With TWIN BLADE reversible knives you can achieve double the service life because you always have replacements on board. Another unique feature amongst balers.

- Replacement knives are always on board.
- Double the service life – long term uniform chop consistency
- Sharp knives reduce the power required to drive the knife bank by around 20 %.



Reliability

Our customers put their trust in our reliability and with the PÖTTINGER IMPRESS you get that in double helpings. Firstly because our innovative technology makes each working step easier by making operation a lot more convenient. Secondly because we offer the unique advantage of reliability in all situations, ensuring that you make the most of the IMPRESS's unbeatable technical features regardless of which material you are baling and in which conditions you are working.

The PÖTTINGER pick-up is controlled from both ends by a steel cam track.

- The tines are slightly trailing to sweep in a controlled arc and adapt ideally to contours. As a result clean forage is guaranteed.
- The fully active tine length up to the withdrawal point ensures the forage is transferred to the rotor perfectly.

For all operating conditions



Convenience

Agriculture needs straightforward operations. While we cannot relieve our farmers and contractors of their work, we can make it easier. We do that by redefining the quality of life with our innovative standards. The IMPRESS round baler demonstrates how performance and convenience can work together perfectly.

The IMPRESS models feature an EASY MOVE knife bank that pulls out to the side. This offers the highest level of safety and convenience. Maintenance takes place at workbench height outside the bale chamber, away from the hazardous area of the round baler. The higher the number of knives, the greater the importance the ease of maintenance becomes. The PÖTTINGER IMPRESS provides an ingenious and convenient solution.

Round balers



Fixed chamber round balers

The fixed chamber on the F models has 18 chain-driven rollers to form uniform, high-stability bales. The front seven rollers make sure the bale rotates in every situation, even with straw.

The material to be baled is compressed until the pressure on the tailgate sensor reaches the pressure set on the terminal. Binding takes place automatically or at the touch of a button, depending on the setting.

Balers with variable bale chambers

The variable chamber models have three endless belts with a hydraulically-adjustable pressure-controlled belt tensioner. The three endless belts make sure the bale rotates in every situation, even with straw. Bale diameter and density can be set from the driver's seat. A variable baler for the whole year with 32 knives for all operating conditions.



Baler & wrapper combinations

The best forage quality thanks to finished bale being wrapped immediately. Direct wrapping, continuous loading or double bale placement with the new baler & wrapper combinations.

- Highest performance thanks to short stopping times.
- Control centre on wrap carrier for bale diameters between 3.6 ft and 4.92 ft / and 1.10 and 1.50 m.



IMPRESS F

The fixed chamber balers have 18 chain-driven rollers to form uniform, highly stable bales.

	System	Bale diameter ft / m	Knives / spacing inch / mm	Power requirement
IMPRESS 125 F MASTER	Fixed bale chamber	4.26 – 4.42 / 1.30 – 1.35	16 / 2.83/72	59 kW / 80 HP
IMPRESS 125 F PRO	Fixed bale chamber	4.26 – 4.42 / 1.30 – 1.35	32 / 1.42/36	74 kW / 100 HP



IMPRESS V

The variable chamber balers have three endless belts with a hydraulically-adjustable pressure-controlled belt tensioner. The three endless belts make sure the bale rotates in every situation, even with short chopped crop material.

	System	Bale diameter ft / m	Knives / spacing inch / mm	Power requirement
IMPRESS 155 V	NEW 3 endless belts	2.62 – 5.08 / 0.8 – 1.55	–	59 kW / 80 HP
IMPRESS 155 V MASTER	3 endless belts	2.62 – 5.08 / 0.8 – 1.55	16 / 2.83/72	59 kW / 80 HP
IMPRESS 155 V PRO	3 endless belts	2.62 – 5.08 / 0.8 – 1.55	32 / 1.42/36	74 kW / 100 HP
IMPRESS 185 V	NEW 3 endless belts	2.95 – 6.07 / 0.9 – 1.85	–	59 kW / 80 HP
IMPRESS 185 V MASTER	3 endless belts	2.95 – 6.07 / 0.9 – 1.85	16 / 2.83/72	59 kW / 80 HP
IMPRESS 185 V PRO	3 endless belts	2.95 – 6.07 / 0.9 – 1.85	32 / 1.42/36	74 kW / 100 HP



IMPRESS PRO baler & wrapper combinations

Direct wrapping, continuous loading and double bale placing An innovative, fast, high throughHPut wrapper to match the high output baler. Control centre on wrapper film dispenser for bales between 3.6 ft and 4.92 ft / 1.10 m and 1.50 m diameter.

	System	Double wrapper arm	Hydraulic performance	Power requirement
IMPRESS 125 FC PRO	Fixed bale chamber	36 rpm	60 l/min, 180 bar	96 kW / 130 HP
IMPRESS 155 VC PRO	3 endless belts	36 rpm	60 l/min, 180 bar	96 kW / 130 HP
IMPRESS 185 VC PRO	3 endless belts	36 rpm	60 l/min, 180 bar	96 kW / 150 HP

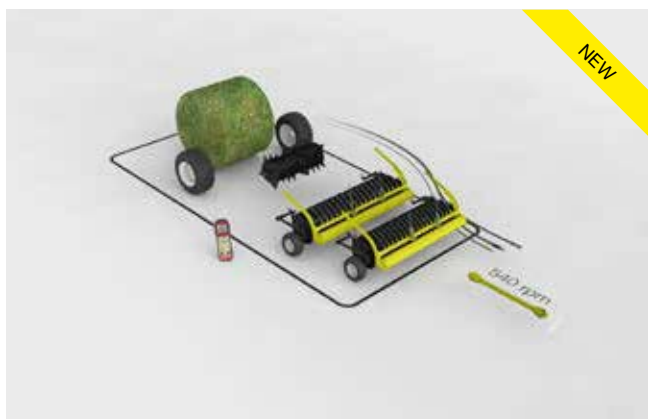

IMPRESS

The PÖTTINGER IMPRESS models without a knife bank are available with a variable bale chamber.

- Feed rotor
- No knife bank
- PTO speed: 540 rpm
- Pick-up width: 6.72 ft / 2.05 m optional 7.54 ft / 2.30 m
- Terminal: SELECT CONTROL
- Standard tyres: 380/55-17



IMPRESS MASTER

The PÖTTINGER IMPRESS MASTER models are available with a fixed or variable bale chamber.

- Chopping rotor
- Chopping system with 16 knives
- PTO speed: 540 rpm
- Pick-up width: 6.72 ft / 2.05 m optional 7.54 ft / 2.30 m
- Terminal: SELECT CONTROL
- Standard tyres: 500/50-17

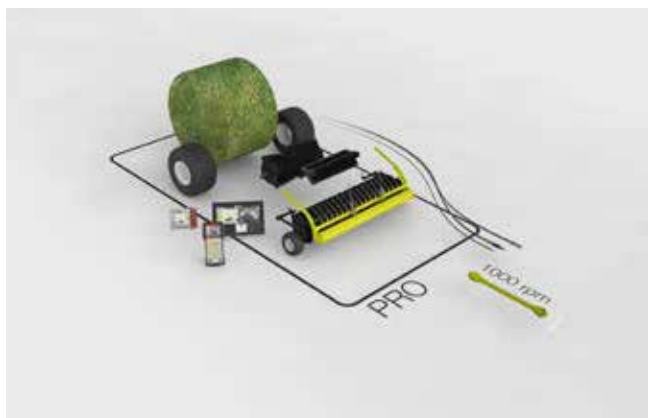

IMPRESS PRO

On IMPRESS PRO models the standard pick-up width is 7.54 ft / 2.30 m.

- Short chop rotor
- Chopping system with 32 knives
- PTO speed: 1000 rpm
- Pick-up width: 7.54 ft / 2.30 m
- Terminal: POWER CONTROL, optional EXPERT 75 / CCI 1200.
- Standard tyres: 500/50-17 (FC/VC: 520/50 R 22.5)

Everything under control



PÖTTINGER's convenient control terminals make sure you have everything under control, even after a long day in the field. The development of our terminals focussed on maximum operating convenience, ergonomics and automation of each working step. The result is a range of control systems that are ideally matched to meet your requirements.



Convenient operation without ISOBUS

The CONTROL terminals made by PÖTTINGER make your day in the field easier. Intuitive machine operation is ensured by the clearly labelled keys and the ergonomic design. This enables stress-free work, even on long working days. The backlit keys and adjustable brightness display ensure safe operation even at night.



SELECT CONTROL

With the electronic preselect system SELECT CONTROL, all functions of the implements to be operated can be preselected and then carried out using the tractor's spool valves. SELECT CONTROL is used for mowers, loader wagons and balers.

CONTROL terminals without ISOBUS



COMPASS CONTROL

The COMPASS CONTROL on-board computer was specially developed for PÖTTINGER VITASEM and AEROSEM seed drills. The terminal controls and monitors functions such as tramlining, calibration test, hopper level, hectare counter and speed.



DIRECT CONTROL

The convenient electronic DIRECT CONTROL system is used especially for the PÖTTINGER loader wagon range without unloading beaters. The functions are performed directly at the push of a button without pre-selection or an additional control unit. The display provides information about the functions and status of the loader wagon.



POWER CONTROL

With the POWER CONTROL terminal you can operate all ISOBUS-compatible PÖTTINGER machines. The functions are performed directly at the push of a button without pre-selection or an additional control unit. The most important keys are labelled directly with the machine-specific functions – which helps drivers regardless of whether they have used the machine before or not. The function keys F1 to F4 can be used to operate additional equipment on your machine. The colour display provides at-a-glance information on functions and the operating status of the machine.



POWER CONTROL Wireless

POWER CONTROL Wireless enables convenient operation of the loader wagon even outside the tractor cab up to a range of 100 metres. The holder doubles as the charging station. This makes the terminal a reliable support for the farmer even during long days in the field.

Everything under control

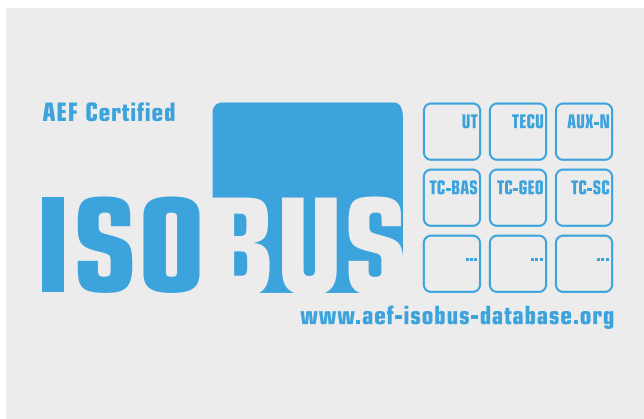

ISOBUS terminals

ISOBUS refers to the standardized communication system between tractor and implement using standardised hardware and software that is not limited to a single manufacturer: This really makes your daily work a great deal easier.

The ISOBUS terminals EXPERT 75 and CCI 1200 enable professional operation of all ISOBUS-compatible machines made by PÖTTINGER as well as other manufacturers.

EXPERT 75

The compact 5.6" EXPERT 75 ISOBUS terminal can be operated both directly via the touchscreen and using keys or a scroll wheel. Safe one-hand operation is supported by the grip bar. The ambient light sensor and the illumination of the function keys ensure convenient handling even at night.



NEW: CCI 1200

The new 12" CCI 1200 ISOBUS terminal offers the professional farmer a comprehensive function package. The terminal is operated like a tablet using a touchscreen. Navigation is kept simple so you find what you need with just a few taps. The integrated ambient light sensor automatically adjusts the brightness of the display.

- The display can be positioned either horizontally or vertically depending on your preference or the space available in the tractor cab. In addition, the screen can be split so that several applications can be displayed simultaneously; you can adjust the size of each window.
- A camera image can also be displayed at the same time as the machine status and controls, so no switching is necessary.
- The innovative help system enables the driver to find out about the application currently opened, its functions and its settings, at any time.

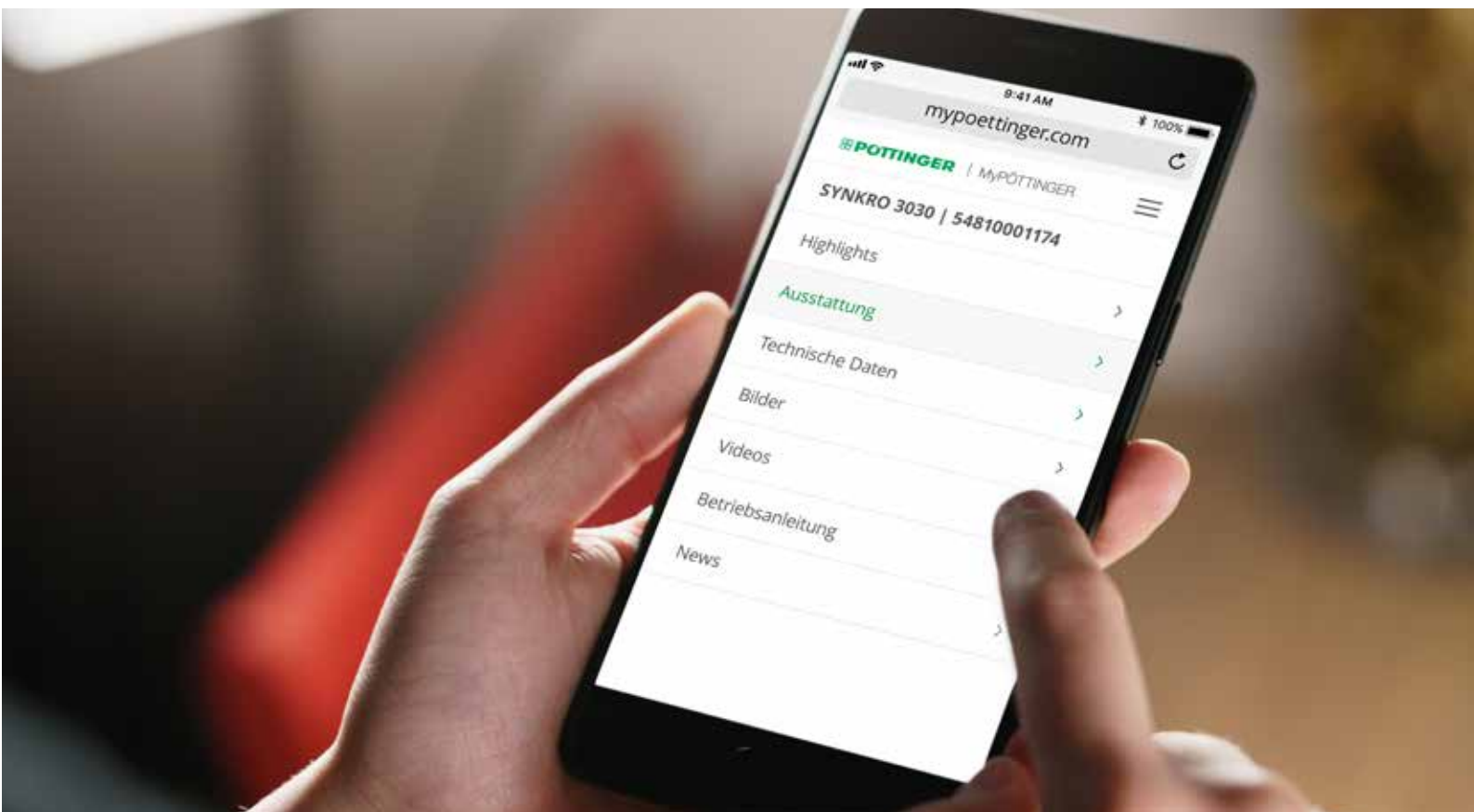

MyPÖTTINGER – Simple. Anytime. Anywhere.

For all PÖTTINGER machines 1997 models onwards

We have created PÖTPRO as a tool to provide machine-specific information for all machines from year of build 1997 onwards.

Simply scan the QR code on the data plate with your smartphone or tablet or enter your machine number at www.mypoettinger.com

Your machine goes online.

All the information on your machine.

You will immediately receive all the information on your machine.

- Instruction manual
- Optional equipment information
- Brochures
- Photos and videos.

Wear parts



Rely on the original

PÖTTINGER Original Parts meet the highest demands in terms of functionality, reliability and performance. These are characteristics that PÖTTINGER is committed to delivering.

That is why we manufacture PÖTTINGER Original Parts from the highest quality materials. We ideally match each individual spare part and wear part to your machinery's overall system. This is because different soil and operating conditions often need to be taken into consideration. We have been listening to our customers and now offer three different lines - CLASSIC, DURASTAR and DURASTAR PLUS - to make sure you have the right part to meet every requirement. Original parts are worth every cent, because know-how cannot be copied.

Your advantages

- Immediate and long-term availability.
- Maximum durability thanks to innovative production processes and the use of the highest quality materials.
- Avoidance of malfunctions due to a perfect fit.
- The best working results thanks to optimum match to the overall system of the machine.
- Save time and costs thanks to longer replacement intervals on wear parts.
- Comprehensive quality testing.
- Ongoing advancement through research and development.
- Worldwide spare parts supply.
- Attractive, competitive prices for all spare parts.



CLASSIC

The classic

The CLASSIC line is for standard duty applications. With these ORIGINAL INSIDE parts we have defined the benchmark for quality, best price/performance ratio and reliability.

- For standard soil conditions.
- For average levels of stress on tools during everyday operation.



DURASTAR

Keeps its promise

DURASTAR is the innovation on the wear components market - durable, high quality, productive and reliable.

DURASTAR parts are ideally suited to every situation in the field where your machines are subjected to demanding conditions. That is because DURASTAR parts deliver what they promise.

- For soil conditions that cause above average wear.
- For tools designed to withstand high stress on contractors' machinery and machinery ring equipment.



DURASTAR PLUS

For the toughest jobs

Are you used to putting your machines to work in the most extreme conditions? Then the DURASTAR PLUS line is the right choice for you.

Excellent performance combined with the highest possible wear resistance is what you get with DURASTAR PLUS parts from PÖTTINGER. Major operations, contractors and farms with extremely high wear conditions - the DURASTAR PLUS line meets all your challenges effortlessly.

- For soil conditions that cause extreme wear.
- Designed for the toughest jobs for large farms and contractors.

Worldwide service network



Service & Spare parts

Durability, reliability and maximum uptime are the key features of PÖTTINGER machines. If technical problems do develop, however, our local dealership is available on-site. PÖTTINGER Customer Service provides support for special technical issues. PÖTTINGER service technicians are on the move for you worldwide.

Worldwide service network - we are where you are

Our dealerships are available on-site as your service partner. In 70 countries worldwide we guarantee to provide you with the best possible service. With our service partners you always have a professional and reliable go-to person at your side. Thanks to ongoing training sessions hosted by PÖTTINGER, the people at our dealerships are experts at handling our machines and provide the basis for your success.

The quick way to the right spare part

You own a PÖTTINGER machine and need the right spare parts and wear parts? No problem: Simply quote the machine number to your dealership. Using the PÖTTINGER spare parts catalogue 'PÖTdoc' and the machine number, they will immediately be able to find the parts that were actually fitted to your machine at the time of shipment. This guarantees that the correct spare parts are ordered. This new development yet again underlines the importance of service quality at PÖTTINGER.

PÖTTINGER spare parts logistics

Our new spare parts logistics centre in Taufkirchen (Austria) started operation in March 2017.

- 1.53 acres / 6,200 m² storage area.
- More than 50,000 articles.
- Up to 800 orders per day.
- Automated small parts storage.



Technology and Innovation Centre (TIZ)

The TIZ Technology and Innovation centre is the heart of the PÖTTINGER quality assurance system. Machines are tested here for their quality and suitability for field conditions. Research, development and implementation go hand in hand.

The test centre is one of the most modern in the agricultural sector worldwide and has an excellent reputation. Many international manufacturers have their products tested here, including many renowned car manufacturers.

These tests save time and development costs, up to 75 percent compared to testing solely in the field. The performance of a machine over its entire service life, for example, can be ascertained in a short period of time. This ensures maximum reliability in the field. At PÖTTINGER at least two prototypes are built of each new model. One is used for testing in the Technology and Testing Centre while the other is sent out into the field.

The testing facilities at the centre include a 4-post test bed for simulating road transport, a MAST (Multi-Axis Simulation Table), a component test rig for analysing individual parts, a climate chamber, driveline test stands and various electronic testing systems.

In parallel to all these tests, there are comprehensive trials being conducted in the field. The field testing plus the results from the technology centre ensure an optimum experience for the customer. PÖTTINGER's expertise has made us a market leader in process-oriented solutions for a wide range of arable and grassland applications. "We make work easier for our customers and increase their quality of life."



More Success with PÖTTINGER

- A family-owned company since 1871, your reliable partner.
- Specialist for tillage, seed drills, hay and harvesting machines.
- Future-safe innovation for outstanding working results.
- Roots in Austria - at home throughout the world.

Harvest quality

- Healthy soil is one of the key provisions for optimising your yield. We support you in achieving this with our machines.
- Clean, nutritious base forage is the foundation for an efficient dairy business. From mowing through to harvesting, we help you have a positive influence on the quality of your forage.
- Trust in PÖTTINGER. Harvest success.

Ask our sales partners for more information:

PÖTTINGER Landtechnik GmbH
Industriegelände 1
4710 Grieskirchen
Austria
Phone +43 7248 600-0
info@poettinger.at
www.poettinger.at

POETTINGER US, Inc.
393 Pilot Drive
Valparaiso, IN 46383
USA
Phone +1 219 510 5534
Fax + 1 219 707 5412
info@poettinger.us
www.poettinger.us

POETTINGER Canada Inc.
650, Route 112
St-Cesaire, PQ J0L 1T0
Canada
Phone +1 450 469 5594
Fax +1 866 417 1683
info@poettinger.ca
www.poettinger.ca