

Trailed pneumatic seed drill combination
AEROSEM VT

 **PÖTTINGER**

Conserves the soil,
compact and manoeuvrable



Conserves the soil, compact and manoeuvrable



All information on technical data, dimensions, weights, output, etc. and the images shown, are approximate and are not binding. The machines shown do not feature country-specific equipment and may include equipment that is not supplied as standard, or is not available in all regions. Your PÖTTINGER dealership would be pleased to provide you with more information.

The trailed AEROSEM seed drill concept combined with active tillage from PÖTTINGER combines high output performance with flexibility. Soil conservation and perfect placement of the seed are the most important factors. We guarantee this with our precision universal metering system and ingenious, robust coulters. The newly developed trailed power harrow and seed drill system also offers us the possibility of sowing a mixture of components at the same time.

Table of contents

The best soil	4
For optimum plant growth	4
Conserves the soil, compact and manoeuvrable	6
Flexible in operation	8
Power harrow & seed drill combination	10
Coulter competence for high output	12
The advantages at a glance.	14
Digital agricultural technology	16
Control terminals	16
Profiline comfort control system	18
agrirouter – data transfer	20
Equipment options	22
Metering wheel selection	22
More equipment options	23
Technical data	24

The best soil

For optimum plant growth



The basis for your success

The soil is the basis for agriculture and forestry and is one of the world's most important yet limited resources. Soils are the essence of our life since they provide the basis for nutrition for us and our livestock. Healthy soil is the prerequisite for optimising your yield.

There are many factors involved in sowing. The optimum sowing time depends on the type of plant, the duration of sunshine, and on temperature. These factors influence, among other things, the choice of variety in crop production and crop rotation. Only exact and uniform seed placement combined with optimum covering of the seed guarantees homogeneous seed germination.

AEROSEM – pure reliability for precise seed placement

The seed drill concept with active seedbed preparation delivers an impressive performance with its precision universal metering and optimised coulter system to guarantee exact seed placement. Conserving the soil during high output operation, sowing is performed cost effectively with only a low drive power requirement.

Each feature on PÖTTINGER's AEROSEM VT is designed to increase productivity. At the end of the day you increase your profit.

- Perfect ground tracking for successful drilling
- Compact design with soil conserving packer
- Perfect seedbed preparation with medium or heavy LION power harrows
- Coulter technology for large area output and a uniform, clean seed slot
- Pressurised hopper system for greater flexibility



Successful drilling

Optimum plant density

It is essential that each individual plant has the space it needs. Growth is determined by the soil conditions, light, water and nutrients. You lay the foundation for a successful harvest when sowing with your AEROSEM seed drill

The proven coulter rail with DUAL DISC coulter system ensures an ideal plant density for your crop. With a row spacing of 12.5 cm, optimum plant development is ensured and weeds are largely suppressed.

Perfect seed placement

“We chose a powerful yet simple seed drill with unique manoeuvrability. The low power requirement is impressive and is reflected in the much lower fuel consumption. The power harrow does a great job on our soil, which is often very heavy. The coulter rail ensures perfect seed placement and germination of the seed. The single shoot system offers us a huge advantage because the plants get a head start with fast growth. PÖTTINGER continues to provide impressive customer service and support right down the line.”

The Langhoff family
Farmers
Stenderup | Denmark

Conserves the soil, compact and manoeuvrable



Ultimate soil conservation

With its large central packer, the AEROSEM VT stands for ultimate soil conservation. Only low lifting forces are required on the tractor.

Grooved tyre packer

The full-length grooved tyre packer with 800 mm diameter wheels covers the full width of the packer, conserving the ground at the headland without smearing the soil. The large dimensioned packer minimises the rolling resistance and avoids the bulldozing effect.

A large contact area in combination with the special grooved profile ensures optimum consolidation of the seed rows.

Front tyre packer

- Three section central packer at the drawbar
- Controlled by central lifting system so packer sections are combined with headland hydraulics
- In addition to providing uniform consolidation, it also actively guides the power harrow
- Front packer is hydraulically pre-tensioned (500 kg per metre of working width) and alleviates the weight acting on the drawbar and the grooved tyre packer

Compact

The 5-metre-wide seed drill measures just 7.5 metres in length with the pre-emergence markers, while the 6-metre-wide machine is 8.2 metres long. Positioning the seed hopper on the drawbar optimises the weight ratio with a low and short construction. The result: a machine that is clearly laid out.



Manoeuvrable

An extremely short design, the intelligent configuration of the seed hopper and the use of compact tractors give the seed drill excellent manoeuvrability. Even with dual wheels, it is possible to turn straight into the next pass. The shortened, low design of the hopper and the integration of the packer into the chassis ensure fast, space-saving turns at the headland.

- Mounting yoke with pivot point set further back for improved track following properties
- Lower linkage position raised at sides to allow space for the PTO shaft up to a 90° turning angle

Stable headland position

The entire machine is raised on the grooved tyre packer at the headland using the chassis and coulter pressure cylinders. Both the power harrow and the coulter rail are brought into the headland position one after the other, guided by a parallelogram. The ground clearance of the power harrow is a remarkable 27 cm.

Because the power harrow is integrated into the support frame structure, there are fewer moving parts and you benefit from increased ease of maintenance.

Flexible in operation



Flexible operation with single shoot

This seed drill combination with pressurised hopper system delivers even greater flexibility. The pressurised hopper is positioned lengthwise and has a capacity of 2,800 litres or 4,600 litres, divided 50:50 in the direction of travel. Each side of the hopper features a separate metering unit – but feeds the same single shoot seed line.

The two metering units can be controlled independently of each other. Two components can be applied simultaneously in a maximum ratio of 1:5. Moreover, two application maps can be used for site-specific drilling.

Pressurised hopper system

The AEROSEM pressurised hopper system is designed for the highest possible output and ensures that exactly the right flow rate of any given seed type is used, even in the most difficult operating conditions.

The agronomic advantage

- Targeted placement of mineral fertiliser in the seed band e.g. sulphur fertilisation for wheat, starter fertilisation for malting barley, etc.
- Mixture of original and farm saved seed or mixture of different dressing grades
- Sowing a companion crop for cereals without segregation of the seed
- Planting different cover crops with different seed sizes

IDS distributor head

The unique IDS system (Intelligent Distribution System) controls all outlets via the bus system. This opens up completely new capabilities in coulter pipe and tramline switching. With active tramline switching the seed rate is automatically reduced for a seed saving of up to 6%.

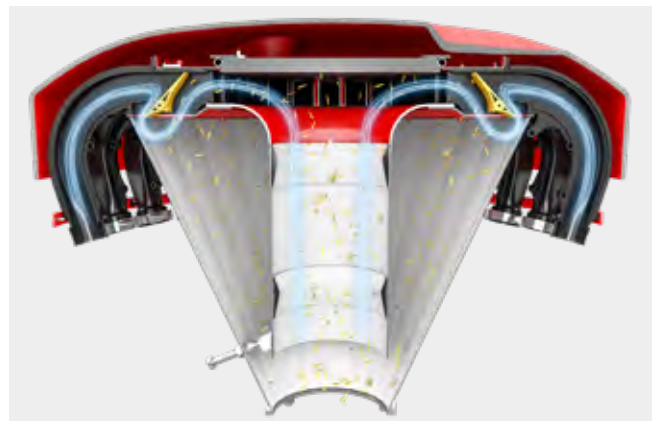

Precise and uniform thanks to optimum lateral distribution

The seed is fed uniformly to the distributor in an air stream that passes up the high riser tube. The large diameter of the distributor head guarantees precise lateral distribution of the seed.

Distributor head inserts

- Simple extension of the row spacing using a choice of inserts
- 2-fold, 3-fold or 4-fold row spacing possible
- Efficient expansion of function to sow root crops
- Precision seed distribution with reliable air separation while maintaining germination capacity
- Recommended also on IDS distributor heads with permanent row shut-off to minimise the grain impact frequency

Reliable & convenient: Tramline system

Tramline switching is performed electronically using actuator motors. Straightforward setting and monitoring functions using the terminal – no need to change hoses around.

Tramline switching can be symmetrical, asymmetrical or custom.

- Flaps on the distributor return the seed to the riser tube so that overall seed output by the metering system is reduced.
- Thanks to the free choice of track widths, tramline widths and tramline rhythms, the AEROSEM is perfectly suited for contract work.
- Manual half width switching left and right

Power harrow & seed drill combination



LION power harrows

The top priority in seedbed preparation is the creation of optimum germination and growth conditions to ensure rapid and uniform plant emergence. PÖTTINGER achieves this goal by using medium-weight or heavy LION power harrows.

Thanks to its proven rotor beam technology, a large-dimensioned central gearbox and integrated tine carriers, the LION provides the basis for optimum sowing.

The integration of the power harrow as a frame component of the machine results in the PTO shaft to the central gearbox always being in a straight line. Designed for maximum reliability during continuous operation, the external gearboxes are protected by a cam-type clutch.

Straightforward hydraulic configuration

The AEROSEM VT features an impressively simple hydraulic configuration. All the machine's functions can be operated using just three double-acting spool valves. In addition, a single-acting spool valve with open return is needed to drive the fan.

The double-acting spool valves are required for lifting and lowering the machine, adjusting the working depth of the power harrow and for the preselect functions. Folding, pre-emergence marker and bout marker are preselect functions that are easily operated using the control terminal in the tractor cab.



High volume seed hopper

- High volume double hopper divided 50:50 with 2,800 litres (VT 5000) or 4,600 litres (VT 6000) and two metering units
- Pressurised hopper system for highest output rates
- Hopper cover moves to the side on smooth-running kinematics
- Level sensors fitted as standard
- Interior lighting fitted as standard

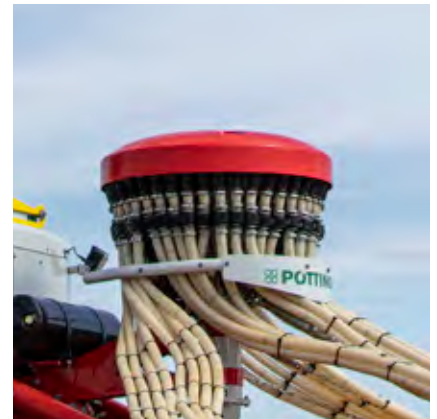

Convenient handling

- Improved accessibility and an optimal overview thanks to the longitudinally mounted hopper
- Full-length hopper cover is moved to the side during filling
- Low filling edge height: 2.17 or 2.57 metres
- Large hopper opening: 1.22 x 1.92 m or 1.22 x 2.40 m
- Good accessibility using the side-folding loading platform
- Residual seed material is conveniently emptied from the side

Easy to use metering units

- Straightforward calibration procedure thanks to easily accessible metering units and calibration at the push of a button
- Metering system components are located in front of the tillage tools for optimum dust protection
- The system is protected against dirt ingress because the fan is integrated into the front wall of the hopper
- Metering wheel drive with wide speed range – no gear changes necessary
- Shut-off plate for straightforward metering wheel replacement
- Simple metering wheel selection using the METERING WHEEL ASSIST app or control terminal
- Toolbox for calibration bags, weighing scales and metering wheels

Reliable seed flow monitoring

The optional seed flow sensors display constant and reliable feedback on the current seed flow at the control terminal.

One sensor per coulters pipe is located directly behind the IDS distributor head, to ensure reliable application. The sensitivity can therefore be adapted to each type of seed. If the flow is not constant, the relevant row number is displayed on the control terminal. Furthermore, red and green LEDs indicate the status directly on the sensors.

Coulter competence for high output



Coulter competence for high output

Successful sowing is dependent on perfectly-matched coulters for opening the seed slot, uniform seed placement and covering the seed again. A well-formed seed slot is essential for successful drilling.

PÖTTINGER provides you with exactly the right coulters for your needs – our double disc coulters guarantee optimum seed placement and uniform emergence. They deliver impressively precise seed placement even in the most difficult conditions.

Intelligent coulters rail docking

The three-section coulters rail is connected to the grooved tyre packer using a separate parallelogram. This ensures optimum contour tracking – even in the most difficult conditions.

In addition to the placement depth, the coulters rail cylinders also apply the coulters pressure. As standard this is set using a pressure relief valve. The valve is coupled to the hydraulic line that supplies the hopper fan, so uniform coulters pressure is achieved even in bumpy terrain. The pressure on the coulters rail is automatically relieved when the fan is switched off.



DUAL DISC double-disc coulters

The large coulters are slightly offset and form a clean and tidy seed slot. The maintenance-free, equal length coulters arms with an offset of 30 cm ensure maximum reliability even with a high level of plant residues. With up to 60 kg applied to each seed coulters, they are guaranteed to slice right through. The V-shaped seed slot prevents the seed from rolling.

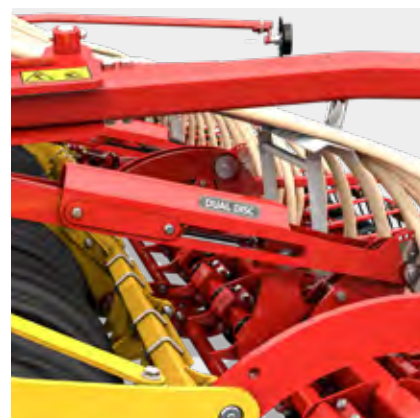
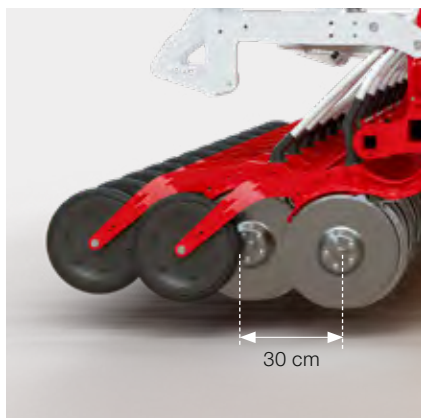

Your advantages:

- Best clearance thanks to 30 cm coulter offset
- Reliable operation in mulch drilling conditions thanks to 350 mm diameter disc coulters and off-set position
- Consistent coulter pressure because coulter arms are all the same length
- Optimum plant distribution density with a row spacing of 12.5 cm
- Optimum depth control thanks to large dimensioned press wheels
- Reliable operation in the most difficult conditions thanks to integrated hardened scrapers on the shares
- Central coulter pressure adjustment

Placement depth adjustment

The working depth is conveniently set on each coulter rail cylinder using an easily accessible lock pin system. Using the ratchet wrench provided, the working depth can be precisely adjusted over a 19-hole matrix. The adjustment range is 0 to 8 cm.

Consistent coulter pressure

In addition to lifting and lowering the coulter rail, the coulter rail cylinders are also responsible for building up the coulter pressure. By twisting the coulter linkage, the equal-length coulter arms are pretensioned using maintenance-free rubber elements. Because the coulter pressure is linked to the fan, the pressure can be adapted flexibly to uneven ground. If excess pressure builds up in the coulter rail cylinders, it is relieved through the fan return line, which is pressureless.

The advantages at a glance



1 Mounting

A mounting yoke shifted further back with Cat. 3 lower linkage guarantees tight turning manoeuvrability. The lower linkages are raised at the side to provide plenty of space for the PTO shaft.

- Turning angle of up to 90° possible
- No collision with PTO shaft

2 Metering

The pressurised hopper system has become standard on the AROSEM VT. Two metering units with electric drives ensure maximum flexibility. Convenient side access saves time for calibration.

- Single shoot ready
- Designed for the highest capacities

3 Seed hopper

The low and compact seed hopper is divided 50:50 along the centreline.

- 2,800 or 4,600 litre capacity
- Filling height of 2.17 or 2.57 m

4 Power harrow

The LION power harrow creates a fine seedbed to meet the highest specifications.

- Hydraulic working depth adjustment
- Two-section construction of the power harrow and three-section configuration of the packer and coulters rail deliver optimum ground tracking
- Integrated pressure accumulators guarantee uniform working depth

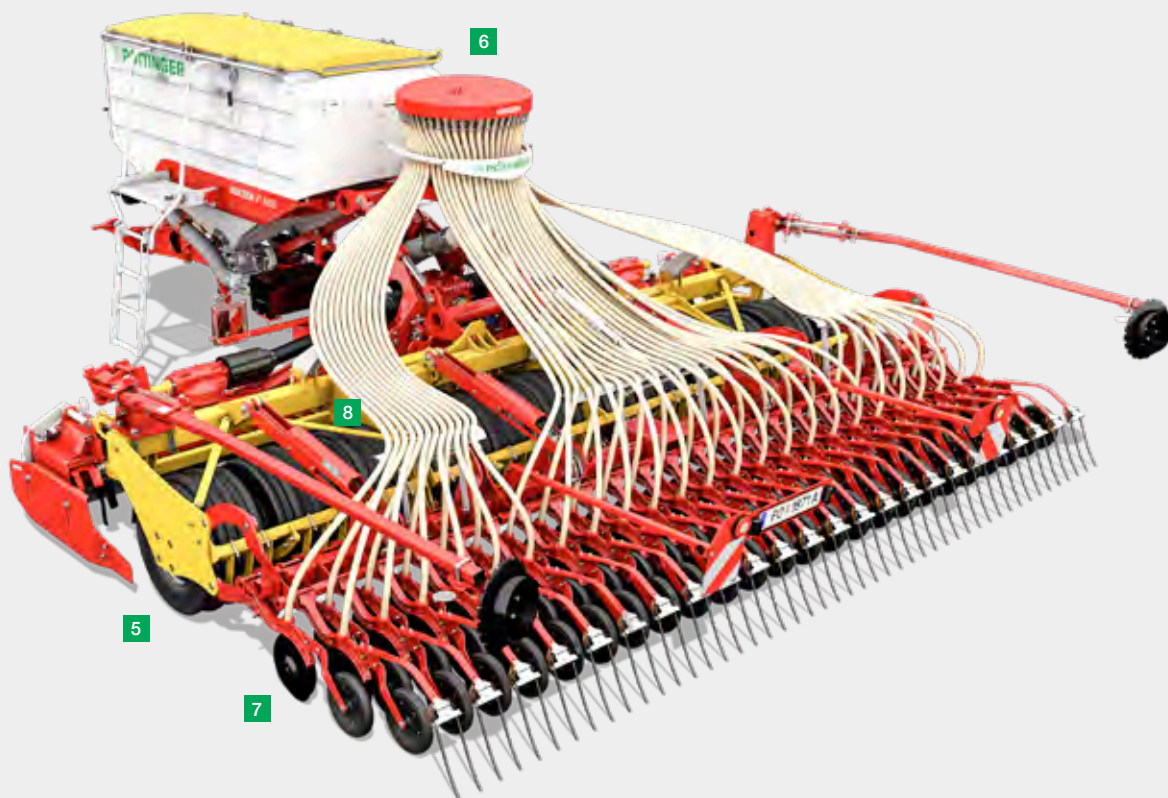

5 Packer unit

The grooved tyre packer is also the main chassis. During operation and at the headland, the weight of the machine is supported by the full width of the packer to conserve the soil.

- No compaction at the headland
- No smearing of the soil surface
- Optimum consolidation of the seed slot
- 400/50 R 15.5 tyres with a diameter of 800 mm

6 Distributor head

The distributor head is located well forward to create very good lateral distribution. Seed lines are all similar in length for uniform seed distribution.

- Uniform distribution for the highest precision
- Tramline rhythms can be selected independently of the seed drill width with the full IDS system

7 Coulter rail

The DUAL DISC coulter rail with double disc coulters has proven its worth over the years and is integrated into this system. A narrow seed slot ensures reliable emergence.

- Double disc coulters with a diameter of 350 mm
- Row spacing 12.5 cm
- Coulter offset 30 cm

8 Coulter pressure

Adjustable coulter pressure is required in order to be able to drill successfully in all conditions in a wide variety of arable farming regions.

- Consistent coulter pressure up to 60 kg
- Adaptive coulter pressure even in bumpy terrain

Digital agricultural technology

Control terminals



Conserving resources

Section Control and Variable Rate Control are available as standard to help operate precisely and efficiently even on long working days. Section Control provides automatic switching over the entire machine width.

In combination with full IDS equipment and an ISOBUS capable control terminal, section control is available. This makes sure that each pass merges tidily, especially at the headland.

By avoiding unwanted overlaps, you save resources, avoid crop growth rate differences, and prevent inconsistent crop densities. Plant disease, weeds and pest infestation are reduced.

Site-specific drilling with SEED COMPLETE

With SEED COMPLETE, PÖTTINGER offers a tool for your success by optimising the management of your farming operations with Section Control and Variable Rate Control.

With Variable Rate Control, the seed flow rate is adjusted to the site-specific conditions using previously created application maps. The AEROSEM VT is able to control both metering units independently of each other with two different application cards.

Site-specific drilling allows seed and fertiliser to be applied according to changing soil conditions. This ensures that all your fields achieve their optimum yield potential.



POWER CONTROL electronic control system

With the POWER CONTROL terminal you can operate all ISOBUS-compatible PÖTTINGER machines. Buttons showing the machine functions make it easy to use.

The newly designed terminal has been optimised in terms of ergonomics and compactness.

- High quality 5" colour touchscreen
- Keys printed with machine functions
- Convenient one-hand operation
- Double-row arrangement of command keys on the right
- Straightforward and intuitive user interface
- Edit using keys and touch-screen
- Compact size – does not obstruct field of vision
- Ambient light sensor and back-lit function keys
- Display the working depth of the power harrow



EXPERT 75 ISOBUS terminal

The PÖTTINGER EXPERT 75 ISOBUS terminal offers high flexibility and enables professional operation of all ISOBUS-compatible machines, regardless of brand.

The terminal has been upgraded in terms of ergonomics and intuitiveness and offers a multitude of advantages.

- High quality 5.6" TFT colour touchscreen
- Rugged, stylish synthetic casing
- Convenient one-hand operation
- Double-row arrangement of command keys on the right
- Straightforward and intuitive user interface
- Edit using keys and touch-screen
- Scroll wheel with confirmation function for direct input and adjustment of set points
- Compact size – does not obstruct field of vision
- Ambient light sensor and back-lit function keys



CCI 1200 ISOBUS terminal

In addition to the features offered by the POWER CONTROL terminal, this system also enables the control of all ISOBUS machines in your fleet, regardless of manufacturer.

- High quality 12" TFT colour touchscreen
- Straightforward and intuitive user interface
- Horizontal or vertical mounting possible
- Large view for best possible monitoring of machine functions
- Customisable layout
- Function pre-select
- Complete supervision of machinery
- Multi-boom compatible terminal
- Section Control and Variable Rate Control as part of SEED COMPLETE package

Simultaneous display of multiple applications

- Camera image and machine functions at a glance
- Simultaneous operation of several ISOBUS machines possible

Digital agricultural technology

Profiline comfort control system



Profiline is the comfort control system that covers all the hydraulic functions of an AEROSEM. The machines are supplied with oil by the tractor's load sensing connection, and all movements are controlled electro-hydraulically via a hydraulic block. The Profiline comfort control system allows the working depth of the power harrow and the coulter pressure of the AEROSEM to be adjusted to match changing conditions in the field while driving.



Rapid attachment

Machines with Profiline comfort control have a pressure line, a pressure-free return and the control line for operating all functions using the tractor's load sensing system. Attaching and parking the machine is done in minutes, saving time.



Convenient operation

While the machines can be operated manually using an ISOBUS capable terminal, their functions can also be automated using Section Control and Variable Rate Control in connection with ISOBUS. All the tools are positioned automatically and precisely. The fan speed and coulter pressure are controlled automatically.



Task Controller Geo

Enabling Task Controller Geo means that application maps can be used to operate the machine. The working depth of the power harrow, coulter pressure, seed and fertiliser rates are then controlled automatically on a site-specific basis. This allows you to use your machines efficiently and save valuable resources.



Precision adjustment

During operation, the tools can be precisely adjusted to the site specific conditions.

Independent of Section Control, the lifting and lowering sequences can also be set based on time or distance travelled.

It is also possible to deactivate individual tools.



Headland control

The headland control function stops and restarts the machine at the headland line. Without a task controller, this function is controlled at the touch of a button. With a task controller, lifting and lowering is done automatically using the TC-GEO/TC-SC signals.

Save time

The intelligent control system allows the vertical travel of individual tools to be limited during lifting because shorter lifting and lowering times mean it takes less time to turn round.

Sensor monitoring enables the machine to fold and unfold automatically.

Digital agricultural technology

agrirouter – data transfer



Manufacturer-independent, wireless data exchange

The agrirouter was developed by DKE-Data GmbH & Co. KG, working together closely with leading agricultural machinery manufacturers like PÖTTINGER. The objective was to create a platform for exchanging data between machines and farm management software. agrirouter is the result. agrirouter is a web-based, manufacturer-independent data platform that enables the exchange of data between machines, farm software and digital apps provided by different manufacturers.



The advantages of the agrirouter

Using the agrirouter offers many advantages for farm businesses. These include manufacturer-independent data exchange, greater efficiency in farm management, process optimisation, and easy-to-use digital documentation.

Data security and transparency

agrirouter displays data to support decision making. Farmers and contractors can choose which data is forwarded to each application.

We are ready for agrirouter

PÖTTINGER provides the capability of transmitting ISOBUS-compliant machine data to the agrirouter.

In addition to seed drills such as VITASEM, AEROSEM and TERRASEM, the machines covered also include rotor loader wagons, round balers, rakes and mowers. Compatible machines are always recognisable by the “ready for agrirouter” sticker.

PÖTTINGER customers can use the agrirouter to send job data from field indexing software or application maps, directly to their CCI 1200 terminal or to PÖTTINGER CONNECT, and save and display data relating to silage bales, for example, on their farm management system.



This QR code takes you directly to the applications.

Equipment options

Metering wheel selection

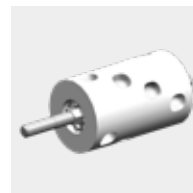
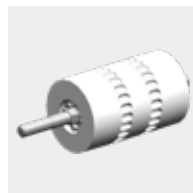
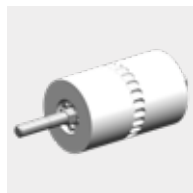
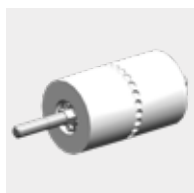
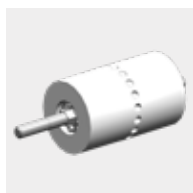

Metering wheel 5
Poppy seed

Metering wheel 7
Poppy seed, oil seed rape

Metering wheel 14
Oil seed rape, phacelia

Metering wheel 28
Phacelia, mustard

Metering wheel 70
Maize, sunflower seed

Seed rate per ha	0.8 - 3 kg	1 - 3.5 kg	3 - 8 kg	7 - 17 kg	6 - 20 kg
VT 5000 DD	<input type="checkbox"/>	<input type="checkbox"/>	<input type="checkbox"/>	<input type="checkbox"/>	<input type="checkbox"/>
VT 6000 DD	<input type="checkbox"/>	<input type="checkbox"/>	<input type="checkbox"/>	<input type="checkbox"/>	<input type="checkbox"/>

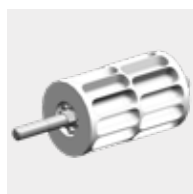
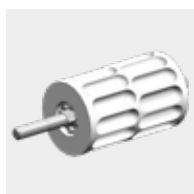
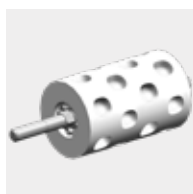

Metering wheel 140
maize, sunflower seed, whole crop forage

Metering wheel 290
Hybrid cereals, wheat, rye

Metering wheel 550
Wheat, barley, oats, rye

Metering wheel 690
Beans, peas, spelt

Seed rate per ha	20 - 30 kg	60 - 80 kg	95 - 275 kg	270 - 360 kg
VT 5000 DD	<input type="checkbox"/>	<input type="checkbox"/>	<input type="checkbox"/>	<input type="checkbox"/>
VT 6000 DD	<input type="checkbox"/>	<input type="checkbox"/>	<input type="checkbox"/>	<input type="checkbox"/>

Metering wheel selection app

To help you find the perfect metering wheel for your seed drill, we have developed an app: METERING WHEEL ASSIST. You can use this app to find the best metering wheel in just a few clicks.

The following QR code takes you directly to the application:



AEROSEM VT

More equipment options



Double hopper system

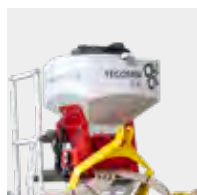

TEGOSEM



Lighting for road transport

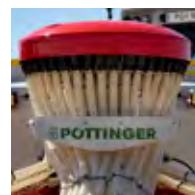

IDS - INTELLIGENT DISTRIBUTION SYSTEM

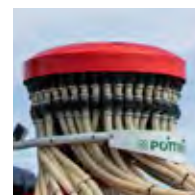

Seed flow monitoring

VT 5000 DD	<input checked="" type="checkbox"/>	<input type="checkbox"/>	<input checked="" type="checkbox"/>	<input type="checkbox"/>	<input type="checkbox"/>
VT 6000 DD	<input checked="" type="checkbox"/>	<input type="checkbox"/>	<input checked="" type="checkbox"/>	<input type="checkbox"/>	<input type="checkbox"/>



Tramline system



Section control



Track eradicators



Bout marker



Front tyre packer

VT 5000 DD	<input type="checkbox"/>	<input type="checkbox"/>	<input type="checkbox"/>	<input type="checkbox"/>	<input type="checkbox"/>
VT 6000 DD	<input type="checkbox"/>	<input type="checkbox"/>	<input type="checkbox"/>	<input type="checkbox"/>	<input type="checkbox"/>

More equipment options

- + Pre-emergence marker
- + Rear levelling board
- + Various metering wheels
- + Scrapers for press wheels
- + Scales for calibration

■ = standard, □ = optional

Technical data



AEROSEM VT

AEROSEM Model	VT 5000 DD	VT 6000 DD
Working width	5.00 m	6.00 m
Seed hopper volume	2,800 l	4,600 l
Hopper partition	50:50	50:50
Filling height	2.17 m	2.57 m
Filling opening	1.22 x 1.92 m	1.22 x 2.40 m
Number of coulters	40	48
Seed row spacing	12.5 cm	12.5 cm
Pressure per coulter	up to 60 kg	up to 60 kg
Coulter disc diameter	350 mm	350 mm
Press wheel diameter	330 mm	330 mm
Number of rotors	20	20
Rotor dimensions	15 x 330 mm	18 x 340 mm
Number of packer tyres	10	12
Rotor Speed	342 rpm	320 - 420 rpm
Packer tyre dimensions	400/50 R 15.5	400/50 R 15.5
Packer wheel diameter	800 mm	800 mm
Transport width	3.00 m	3.00 m
Transport height	3.00 m	3.70 m
Transport length ¹	7.20 m / 7.50 m	7.90 m / 8.20 m
Power requirement kW	147 kW	206 kW
Power requirement hp	200 hp	280 hp
Machine weight	7,600 kg	9,400 kg

¹ Machine length with TEGOSEM / with pre-emergence markers



MyPÖTTINGER – it's easy. Anytime. Anywhere.

Benefit from numerous advantages

MyPÖTTINGER is our customer portal that provides you with key information about your PÖTTINGER machines.

Get specific information and useful tips on your PÖTTINGER machines in "My machines." And find out more about the PÖTTINGER product range.

My machines

Add your PÖTTINGER machinery to "My machines" and assign a name. You will receive valuable information such as: useful tips on your machine, operating instructions, spare parts lists, maintenance information, as well as all the technical details and documentation.

Info on the product range

MyPÖTTINGER provides you with machine-specific information for all machines built starting 1997.

Scan the QR code on the machine's data plate with a smartphone or tablet or go to www.mypoettinger.com and enter the machine number from the comfort of your own home. You will immediately receive all the information on your machine, such as: instruction manuals, equipment options information, brochures, photos and videos.



Rely on the original

PÖTTINGER ORIGINAL PARTS meet the highest demands in terms of functionality, reliability and performance. These are characteristics that PÖTTINGER is committed to delivering.

That is why we manufacture PÖTTINGER ORIGINAL PARTS from the highest quality materials. We ideally match each individual spare part and wear part to your machinery's overall system. This is because different soil and operating conditions often need to be taken into consideration.

We have been listening to our customers and now offer three different lines – CLASSIC, DURASTAR and DURASTAR PLUS – to make sure you have the right part to meet every requirement. ORIGINAL PARTS are worth every cent, because know-how cannot be copied.

Your advantages

- Immediate and long-term availability.
- Maximum durability thanks to innovative production processes and the use of the highest quality materials.
- Avoidance of malfunctions due to a perfect fit.
- The best working results thanks to optimum match to the overall system of the machine.
- Save time and costs thanks to longer replacement intervals on wear parts.
- Comprehensive quality testing.
- Ongoing advancement through research and development.
- Worldwide spare parts supply.
- Attractive, competitive prices for all spare parts.

Wear parts

The CLASSIC line is for standard duty applications. With these ORIGINAL INSIDE parts we have defined the benchmark for quality, best price/performance ratio and reliability.

DURASTAR is the innovation on the wear components market – durable, high quality, productive and reliable.

Are you used to putting your machines to work in the most extreme conditions? Then the DURASTAR PLUS line is the right choice for you.



More success with PÖTTINGER

- Your reliable partner, as a family-owned company since 1871
- Specialist for arable and grassland
- Future-safe innovation for outstanding working results
- Roots in Austria – at home throughout the world

Conserving the soil for perfect sowing results

- Can be used flexibly on different types of soil in varying conditions
- The best seedbed preparation with medium or heavy power harrows
- Perfect consolidation with large grooved tyre packer
- Optimum seed placement thanks to the proven AEROSEM coulter rail
- Unique ground tracking of power harrow, packer and coulter rail

Ask for more information:

PÖTTINGER Landtechnik GmbH

Industriegelände 1
4710 Grieskirchen
Austria
Phone +43 7248 600-0
info@poettinger.at
www.poettinger.at

POETTINGER Australia Pty. Ltd.

11 Efficient Drive
Truganina VIC 3029
Australia
Phone +61 3 8353 2770
info@poettinger.com.au
www.poettinger.com.au

Alois PÖTTINGER UK Ltd.

15 St Marks Road
Corby Northamptonshire,
NN18 8AN
United Kingdom
Phone + 44 1536 272 220
info@pottinger.uk
www.pottinger.uk

POETTINGER Ireland Ltd.

Glenaleamy, Powerstown Road,
Clonmel, Co. Tipperary
Ireland
Phone +353 52 6125766
info@poettinger.ie
www.poettinger.ie

